

## Burner control units BCU 480

### TECHNICAL INFORMATION

- For pilot and main burners in intermittent or continuous operation
- Flame control by UV, ionization or a further option of using the furnace chamber temperature
- Simple system integration using the PC programming and diagnostic software BCSofT
- With optional valve proving system
- Fieldbus connection (PROFIBUS, PROFINET, EtherNet/IP) using optional bus module



# Contents

<b>Contents</b> .....	<b>2</b>	5.2 Proof of closure function .....	38
<b>1 Application</b> .....	<b>5</b>	<b>6 BCSOft</b> .....	<b>39</b>
1.1 Application examples .....	7	<b>7 Fieldbus communication</b> .....	<b>40</b>
1.1.1 Stage-controlled main burner with alternating pilot burner .....	7	7.1 BCU and bus module BCM .....	41
1.1.2 Main burner with permanent pilot burner .....	8	7.2 Configuration, planning .....	42
1.1.3 Two-stage-controlled main burner with permanent pilot burner .....	9	7.2.1 Device master data file (GSD), electronic data sheet (EDS) .....	42
1.1.4 Staged control .....	10	7.3 PROFINET, EtherNet/IP .....	43
1.1.5 Modulating control with defined ignition position .....	11	7.3.1 Modules for process data .....	43
1.1.6 Flame control using the temperature .....	12	7.3.2 Device parameters and statistics .....	48
1.1.7 ON/OFF rotary impulse control .....	13	7.4 PROFIBUS .....	49
1.1.8 Modulating burner control .....	15	<b>8 Program step/status</b> .....	<b>50</b>
1.1.9 PROFINET connection using bus module BCM .....	17	<b>9 Fault messages</b> .....	<b>52</b>
<b>2 Certification</b> .....	<b>18</b>	<b>10 Parameter</b> .....	<b>55</b>
<b>3 Function</b> .....	<b>19</b>	10.1 Application parameters .....	55
3.1 Part designations .....	19	10.2 Interface parameters .....	59
3.2 Connection diagram .....	20	10.3 Scanning the parameters .....	62
3.2.1 BCU 480..E1/LM 400..F3..E1 with ionization control in double-electrode operation .....	20	10.3.1 Flame control .....	63
3.2.2 BCU 480..P3..E1/LM 400..F3..E1 with industrial plug for ionization control in double-electrode operation .....	21	10.3.2 Burner 1 flame signal FS1 switch-off threshold .....	63
3.2.3 Flame control .....	22	10.3.3 Burner 2 flame signal FS2 switch-off threshold .....	63
3.2.4 Assignment of connection terminals .....	24	10.3.4 Flame simulation check in standby position .....	64
3.3 Program sequence .....	26	10.3.5 High temperature operation .....	66
<b>4 Air control</b> .....	<b>27</b>	10.4 Behaviour during start-up .....	69
4.1 Capacity control .....	28	10.4.1 Burner 1 start-up attempts .....	69
4.1.1 BCU..F1 .....	28	10.4.2 Burner 2 start-up attempts .....	70
4.1.2 BCU..F3 .....	29	10.4.3 Burner application .....	71
<b>5 Valve proving system</b> .....	<b>30</b>	10.4.4 Pilot burner .....	74
5.1 Tightness control .....	30	10.4.5 Safety time 1 $t_{SA1}$ .....	75
5.1.1 Test instant .....	31	10.4.6 Flame proving period 1 $t_{FS1}$ .....	75
5.1.2 Program sequence .....	32	10.4.7 Safety time 2 $t_{SA2}$ .....	76
5.1.3 Test period $t_P$ .....	34	10.4.8 Flame proving period 2 $t_{FS2}$ .....	76
5.1.4 Opening time $t_L$ .....	35	10.5 Behaviour during operation .....	77
5.1.5 Measurement time $t_M$ .....	35	10.5.1 Restart .....	77
		10.5.2 Minimum operating time $t_B$ .....	78
		10.6 Safety limits .....	79

10.6.1 Safety time during operation . . . . .	79	10.14.4 Function of contact 95/97 . . . . .	97
10.7 Air control. . . . .	80	10.14.5 Contact 85/86, 87 function . . . . .	97
10.7.1 Over-run time $t_{NL}$ . . . . .	80	10.15 Functions of inputs at terminals 1 to 7 and 35 to 41	98
10.7.2 Running time selection . . . . .	80	10.15.1 Function of input 1 . . . . .	98
10.7.3 Running time . . . . .	80	10.15.2 Function of input 2 . . . . .	98
10.7.4 Over-run . . . . .	81	10.15.3 Function of input 3 . . . . .	99
10.7.5 Air actuator control . . . . .	82	10.15.4 Function of input 4 . . . . .	99
10.7.6 Air actuator on start-up can be activated externally . . . . .	83	10.15.5 Function of input 5 . . . . .	99
10.7.7 Air actuator in the event of fault . . . . .	84	10.15.6 Function of input 6 . . . . .	99
10.7.8 Combustion mode . . . . .	84	10.15.7 Function of input 7 . . . . .	99
10.8 Valve check . . . . .	85	10.15.8 Function of input 35 . . . . .	99
10.8.1 Valve proving system. . . . .	85	10.15.9 Function of input 36 . . . . .	99
10.8.2 Relief valve (VPS) . . . . .	85	10.15.10 Function of input 37 . . . . .	99
10.8.3 Measurement time for $V_{p1}$ . . . . .	86	10.15.11 Function of input 38 . . . . .	100
10.8.4 Valve opening time $t_{L1}$ . . . . .	86	10.15.12 Function of input 39 . . . . .	100
10.9 Behaviour during start-up . . . . .	87	10.15.13 Function of input 40 . . . . .	100
10.9.1 Minimum pause time $t_{MP}$ . . . . .	87	10.15.14 Function of input 41 . . . . .	100
10.10 Manual mode . . . . .	88	<b>11 Replacement possibilities . . . . .</b>	<b>101</b>
10.10.1 Operating time in Manual mode . . . . .	88	<b>12 Selection . . . . .</b>	<b>103</b>
10.11 Sensors . . . . .	89	12.1 Burner control unit BCU . . . . .	103
10.11.1 Function of sensor 1 . . . . .	89	12.1.1 Type code . . . . .	104
10.11.2 Function of sensor 2 . . . . .	89	12.2 Power module LM 400 . . . . .	105
10.11.3 Function of sensor 3 . . . . .	89	12.2.1 Type code . . . . .	105
10.11.4 Proof of closure function test period . . . . .	89	<b>13 Project planning information . . . . .</b>	<b>106</b>
10.12 Communication . . . . .	90	13.1 Installation . . . . .	106
10.12.1 Fieldbus communication . . . . .	90	13.2 Commissioning . . . . .	106
10.12.2 K-SafetyLink . . . . .	90	13.3 Electrical connection . . . . .	107
10.12.3 Safety interlocks (bus) . . . . .	91	13.3.1 Safety current inputs . . . . .	107
10.12.4 Purge (bus) . . . . .	91	13.4 Actuators . . . . .	108
10.12.5 High temperature operation (bus) . . . . .	91	13.5 Parameter chip card . . . . .	108
10.12.6 LDS (bus) . . . . .	91	13.6 K-SafetyLink. . . . .	108
10.13 Interface parameters . . . . .	92	13.7 Overload protection . . . . .	108
10.13.1 Flame control. . . . .	92	13.8 Calculating the safety time $t_{SA}$ . . . . .	109
10.13.2 Air actuator . . . . .	93	<b>14 Accessories . . . . .</b>	<b>110</b>
10.13.3 Function of terminal 64 . . . . .	96	14.1 High-voltage cable . . . . .	110
10.14 Functions of contacts 80 to 97 . . . . .	97	14.2 Industrial plug connector, 16-pin . . . . .	110
10.14.1 Contact 80, 81/82 function . . . . .	97		
10.14.2 Contact 90, 91/92 function . . . . .	97		
10.14.3 Function of contact 95/96 . . . . .	97		

14.3 BCSof4 . . . . .	110
14.3.1 Opto-adapter PCO 200 . . . . .	110
14.4 Connection plug set . . . . .	110
14.5 Set of language stickers . . . . .	111
14.6 Fastening set . . . . .	111
14.7 External securing bars . . . . .	111
14.8 Bus module BCM 400 . . . . .	112
14.9 Flange plates . . . . .	113
<b>15 BCM 400 . . . . .</b>	<b>114</b>
15.1 Application . . . . .	114
15.2 Function . . . . .	114
15.3 Electrical connection . . . . .	114
15.4 Commissioning . . . . .	116
15.5 Installation . . . . .	117
15.6 Selection . . . . .	117
15.7 Technical data . . . . .	117
<b>16 Technical data . . . . .</b>	<b>118</b>
16.1 Electrical data . . . . .	118
16.2 Mechanical data . . . . .	119
16.3 Ambient conditions . . . . .	119
16.4 Dimensions . . . . .	120
<b>17 Converting units . . . . .</b>	<b>121</b>
<b>18 Safety-specific characteristic values for SIL and PL . . . . .</b>	<b>122</b>
<b>19 Safety information in accordance with EN 61508-2 . . . . .</b>	<b>123</b>
19.1 General . . . . .	123
19.2 Interfaces . . . . .	123
19.3 Communication . . . . .	123
19.4 SIL and PL . . . . .	124
<b>20 Maintenance . . . . .</b>	<b>125</b>
<b>21 Legend . . . . .</b>	<b>126</b>

<b>22 Glossary . . . . .</b>	<b>127</b>
22.1 Waiting time $t_W$ . . . . .	127
22.2 Safety time on start-up $t_{SA1}$ . . . . .	127
22.3 Safety time on start-up $t_{SA2}$ . . . . .	127
22.4 Ignition time $t_Z$ . . . . .	127
22.5 Safety time during operation $t_{SB}$ . . . . .	127
22.6 Safety interlocks (Limits) . . . . .	127
22.7 Safety shut-down . . . . .	128
22.8 Safety shut-down with subsequent lock-out (fault lock-out) . . . . .	128
22.9 Warning signal . . . . .	128
22.10 Timeout . . . . .	128
22.11 Air actuator . . . . .	128
22.12 Safe failure fraction SFF . . . . .	129
22.13 Diagnostic coverage DC . . . . .	129
22.14 Operating mode . . . . .	129
22.15 Probability of dangerous failure $PFH_D$ . . . . .	129
22.16 Mean time to dangerous failure $MTTF_d$ . . . . .	129
<b>For more information . . . . .</b>	<b>130</b>

# 1 Application

See also the video “Kromschroder BCU 4 Series – Next-Generation Burner Control Unit” in German, English or Chinese.



The next-generation burner control unit BCU 480 unites the components of automatic burner control unit, ignition transformer, Manual/Automatic mode, display of operating and fault statuses and a user interface (HMI) in a compact metal housing. It replaces the previous product line with the same name. It is suitable for almost every conceivable multiple burner application in the metal, ceramics, food and automotive industries.

It can be used for directly ignited industrial burners of unlimited capacity. The burners may be modulating-controlled or stage-controlled. Installation in the immediate vicinity of the burner being monitored simplifies system integration.

On industrial furnaces, it reduces the load on the central furnace control by taking over tasks that relate to the burner, for example it ensures that the burner ignites in a safe condition when it is restarted.

The air control on the BCU..F1 or F3 assists the furnace control for cooling, purging and capacity control tasks. The burner control unit has an interface via which an air valve or actuator can be controlled for staged or modulating burner capacity control.

The program status, device parameters, error codes, statistics and level of the flame signal can be read easily and conveniently on the four-digit device display.

The burner can be controlled manually for commissioning, maintenance and diagnostic purposes.

Energy management using phase reduces the installation and cabling costs. The valves and ignition transformer are powered by phase L1/the voltage supply for the BCU instead of the safety interlocks.

The monitored outputs for the actuator and valve are housed in the plug-in power module LM 400. This can easily be replaced if necessary.



*Power module LM 400 with connections for valves, actuator and parameterizable signalling contacts*

Thanks to the optionally integrated valve proving system, the valves can be checked for leaks by querying an exter-

## Application

---

nal gas pressure switch or it can be checked whether gas valves are closed.

As an option, the BCU can be configured with high temperature operation. In High temperature mode, the BCU can monitor the flame indirectly using the temperature.

Using the BCSOFT program, the parameters, analysis and diagnostic information can be read from a BCU via the optionally available opto-adapter. If necessary, the device parameters can be adjusted easily using BCSOFT. All valid parameters are saved on an integrated parameter chip card. The parameter chip card can be removed from the old unit and inserted into a new BCU to transfer the parameters, for example when replacing the unit.

The burner control unit is IIoT-compatible using the bus module BCM 400. The BCU can be networked with a standardized fieldbus system (PROFIBUS, PROFINET or EtherNet/IP) using the BCM. Networking in a fieldbus system enables the burner control unit BCU to be controlled and monitored by an automation system (e.g. PLC). This also opens up a wide range of process visualization possibilities.



*Bus module BCM 400 for internal connection to the BCU*

## 1.1 Application examples

### 1.1.1 Stage-controlled main burner with alternating pilot burner

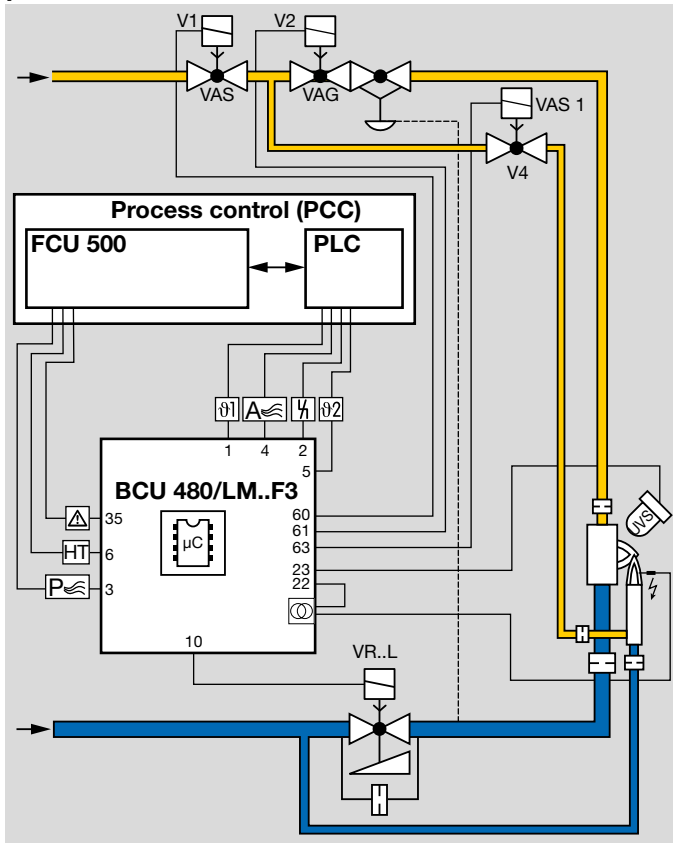

Control:  
Main burner ON/OFF or High/Low

The main burner can be started with reduced capacity after the operating signal from the pilot burner has been detected. The pilot burner is switched off automatically after the main burner has started up. When the main burner is switched off, the pilot burner automatically switches on again. This reduces the main burner start-up time.

The UV sensor monitors the flame signal from pilot and main burners.

The BCU provides the cooling and purging processes.

### 1.1.2 Main burner with permanent pilot burner

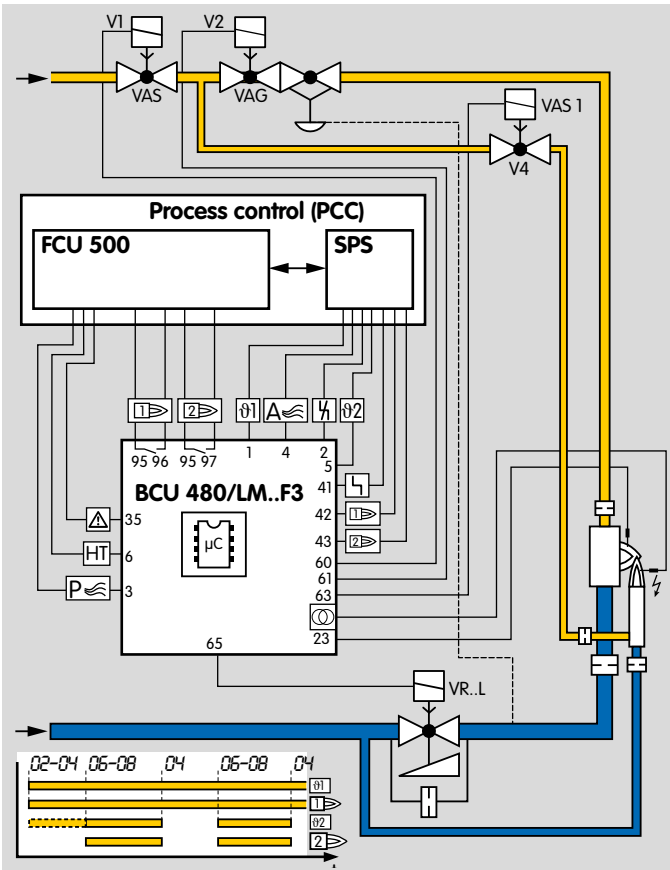

Control:  
Main burner ON/OFF or High/Low

The main burner can be started with reduced capacity after the operating signal from the pilot burner has been detected. Pilot and main burners can be operated simultaneously.

This reduces the time required by the main burner for starting up.

The BCU provides the cooling and purging processes.

### 1.1.3 Two-stage-controlled main burner with permanent pilot burner

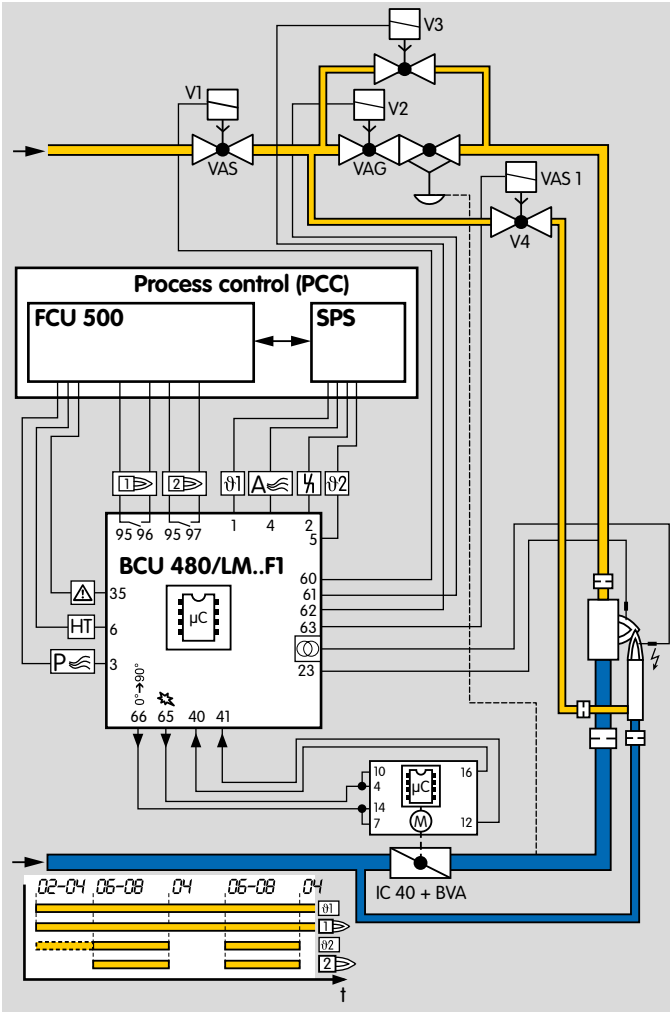

Control:

Main burner ON/OFF with ignition via bypass

The main burner can be started with minimum capacity after the operating signal from the pilot burner has been detected. When the operating state is reached, the BCU issues the enable signal for the maximum burner capacity. Pilot and main burners can be operated simultaneously. This reduces the time required by the main burner for starting up. The BCU provides the cooling and purging processes.

### 1.1.4 Staged control

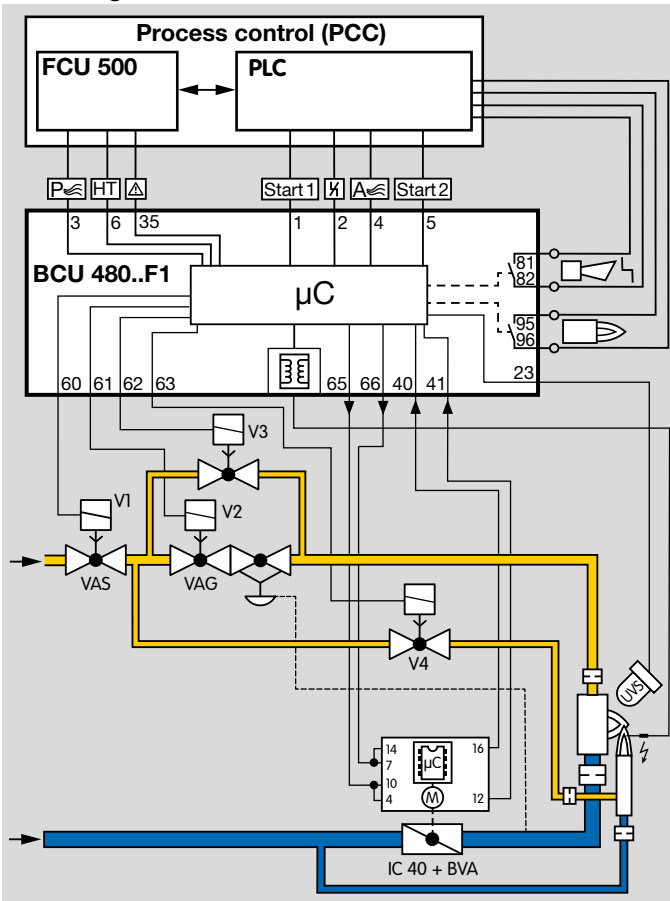

The BCU activates butterfly valve BVA and moves it to the pre-purge position. In the event of a temperature demand, the burner control unit BCU activates input DI 1 via the output at terminal 65 and moves the butterfly valve to the ig-

nitiation position (condition: the IC 40 must have reached the ignition position on the instant of ignition). The burner starts. The burner application “Burner 1 with pilot gas” (parameter A078 = 1) is selected so that the burner can be started with a limited start fuel flow rate. To activate the high-fire rate, DI 2 is actuated via the air valve output at terminal 66 of the BCU. The butterfly valve moves cyclically between the high-fire rate position and the low-fire rate position, see page 93 (Air actuator), Operating mode 11.

DI 1/Term. 65	DI 2/Term. 66	IC 40 position	Valve position
Off	Off	closed	Closed
On	Off	low	Ignition position/Low-fire rate
On	On	middle	High-fire rate
Off	On	high	Pre-purge

### 1.1.5 Modulating control with defined ignition position

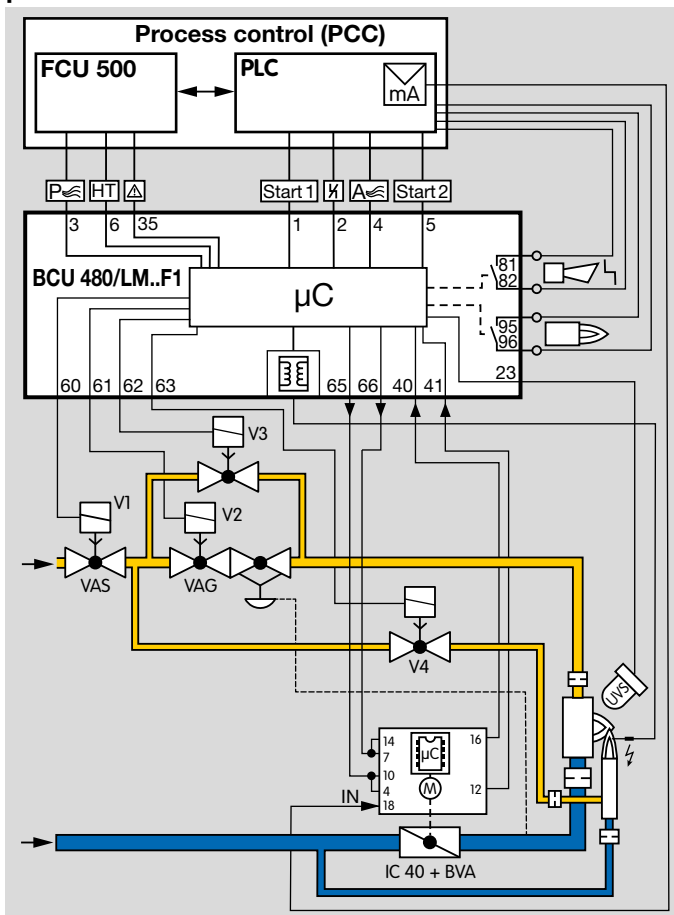

The central control system starts the pre-purge. Input DI 2 is activated via the air valve output of the BCU and the butterfly valve BVA is set to the pre-purge position.

In the event of a temperature demand, the burner control unit BCU activates input DI 1 via the output at terminal 65 and moves the butterfly valve to the ignition position (condition: the IC 40 must have reached the ignition position on the instant of ignition). The burner starts.

The burner application “Burner 1 with pilot gas” (parameter A078 = 1) is selected so that the burner can be started with a limited start fuel flow rate.

During operation, the BCU activates DI 1 and DI 2 using outputs 65 and 66. This enables the analogue input IN on the actuator IC 40. Depending on the capacity demand of the temperature controller, the butterfly valve BVA moves steplessly to the position between the low-fire rate and the high-fire rate as specified by the analogue input IN, see page 93 (Air actuator), Operating mode 27.

DI 1/V1	DI 2/Air valve	IC 40 position	Valve position
Off	Off	closed	Closed
On	Off	low	Ignition position/Low-fire rate
On	On	analogue chart 1	In acc. with chart 1
Off	On	high	Pre-purge/High-fire rate

### 1.1.6 Flame control using the temperature

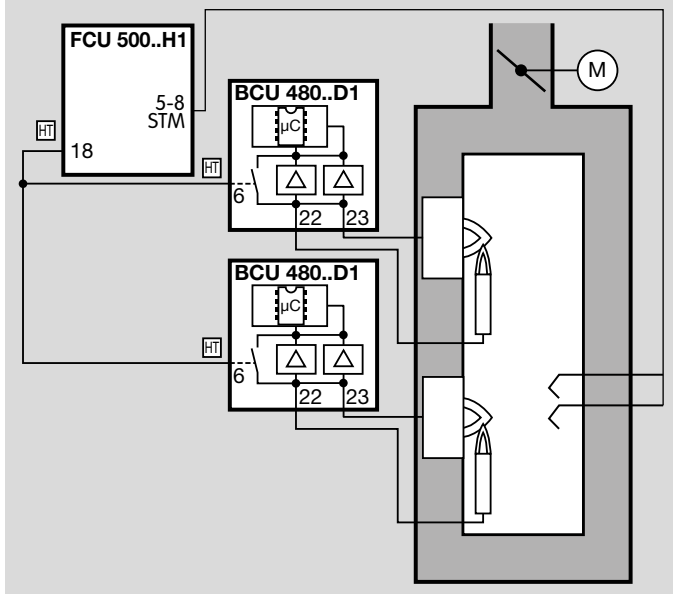

In high temperature systems (temperature  $> 750^{\circ}\text{C}$ ), the flame may be controlled indirectly via the temperature. As long as the temperature in the furnace chamber is below  $750^{\circ}\text{C}$ , the flame must be controlled by conventional methods.

If the temperature in the furnace chamber rises above the spontaneous ignition temperature of the gas/air mixture ( $> 750^{\circ}\text{C}$ ), the FCU signals to the burner control units via the fail-safe HT output that the furnace system is in High temperature mode (HT). When the HT input is activated, the burner control units switch to High temperature mode.

They operate without evaluating the flame signal and their internal flame control systems are non-functional.

If the furnace temperature falls below the spontaneous ignition temperature ( $< 750^{\circ}\text{C}$ ), the FCU disconnects the HT output from the electrical power supply. There is no longer an active signal at the HT inputs of the burner control units. The flame signals are monitored once again by the UV sensor or flame rod.

In the event of a fault in a temperature monitoring component (e.g. sensor discontinuity, sensor short-circuit) or in the event of a mains failure, the flame control task is transferred to the burner control units.

### 1.1.7 ON/OFF rotary impulse control

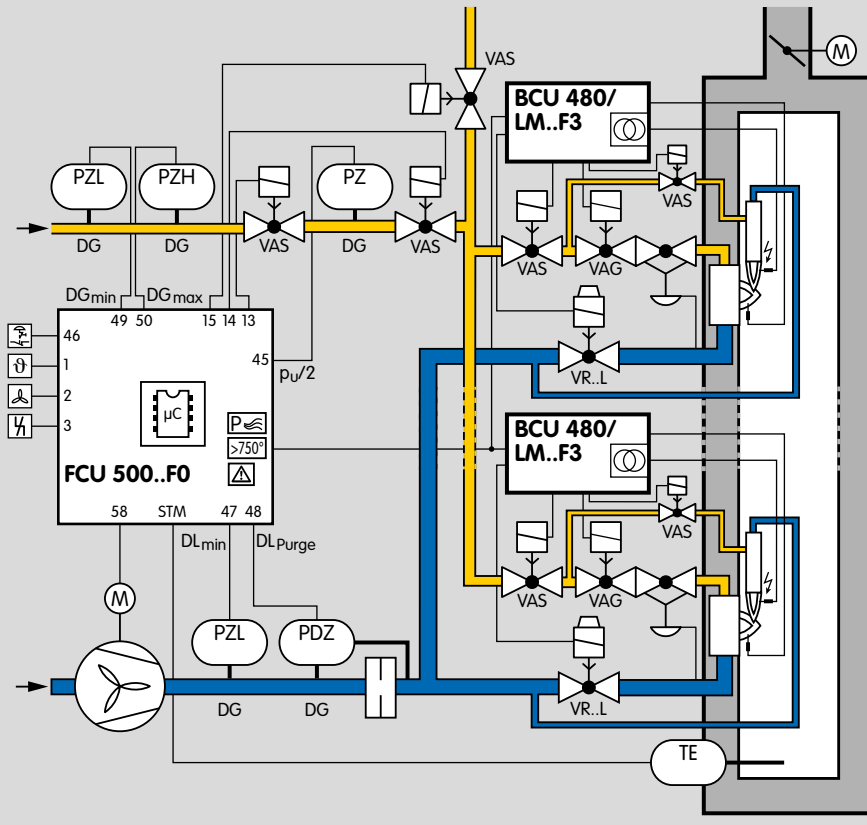

For processes which require a turndown of more than 10:1 and/or those which require heavy circulation of the furnace atmosphere to ensure a uniform temperature, e.g. heat treatment furnaces operating at low and medium temperatures in the metallurgical industry.

With ON/OFF cyclic control, the capacity supplied to the process is controlled by means of a variable ratio of the operating time to the pause time. In this type of control, the burner output pulse frequency always maintains full momentum and results in maximum convection in the furnace chamber, even with regulated heating.

## Application

---

The pneumatic ratio control system controls the gas pressure on the burner proportionally to the air pressure and thus maintains a constant air/gas ratio. At the same time, it acts as a low air pressure protection device.

The ignition and monitoring of the individual burners is ensured by burner control unit BCU 480 with power module LM..F3.

The centrally checked safety functions such as pre-purge, tightness test, flow detector and pressure switch check ( $gas_{min.}$ ,  $gas_{max.}$ ,  $air_{min.}$ ) are provided by the FCU 500.

## 1.1.8 Modulating burner control

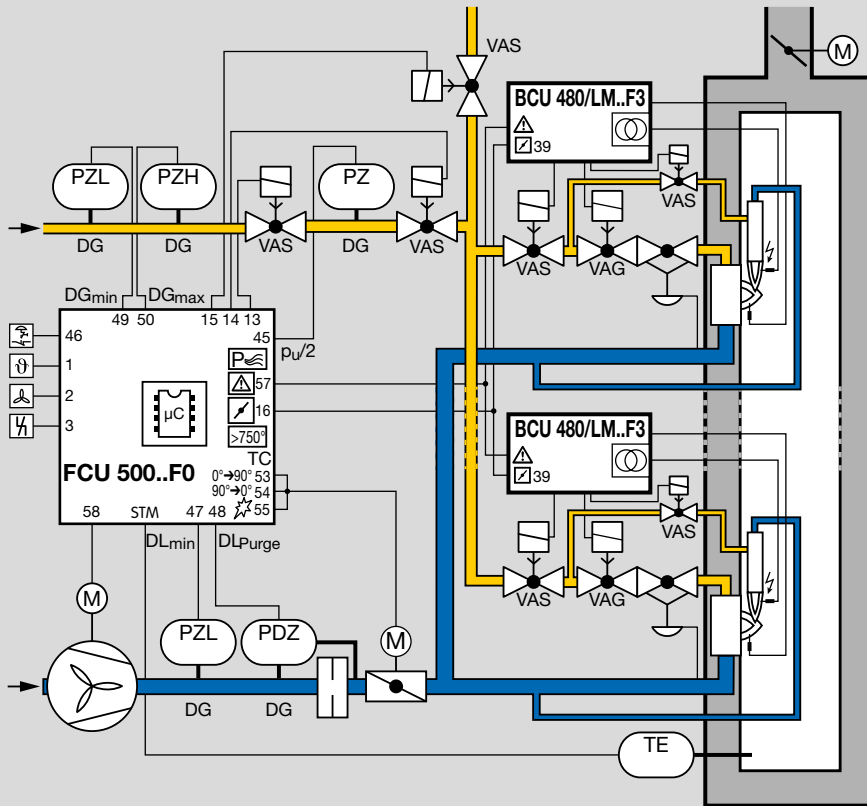

The centrally checked safety functions such as pre-purge, setting the valve to ignition position via a butterfly valve control system, tightness test, flow detector and pressure switch check (gas<sub>min.</sub>, gas<sub>max.</sub>, air<sub>min.</sub>) are provided by the FCU 500. The capacity can be adjusted continuously by activating the control element (analogue or 3-point step signal).

To ensure that the correct air volume is available for ignition (start fuel flow rate) when starting the burners, the FCU sends the burner start enable signal to the BCUs via the “LDS (limits during start-up)” output.

The circuit design of the safety interlock and LDS outputs on the FCU and the corresponding inputs on the BCUs en-

## *Application*

---

ensures that the burners can only start if the safety interlocks and the LDS output have enabled burner start-up.

### 1.1.9 PROFINET connection using bus module BCM

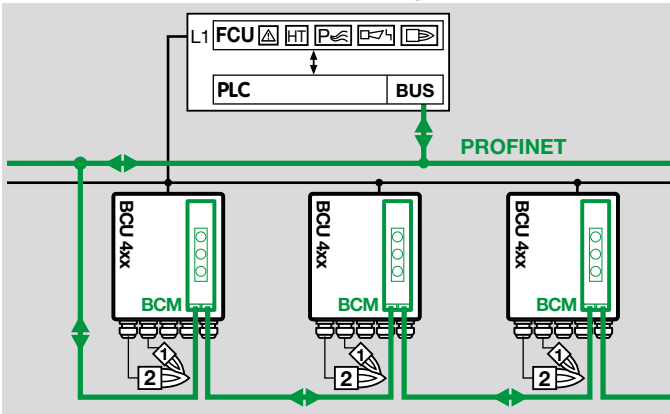

The bus system transfers the control signals from the automation system (PLC) to the BCU/BCM for starting, resetting, controlling the air valve, purging the furnace or for cooling and heating during operation. In the opposite direction, it sends operating status, the level of the flame signal and the current program status.

Control signals that are relevant for safety, such as the safety interlocks, purge and HT input, are wired independently of the bus communication using separate cables.

## 2 Certification

Certificates – see [www.docuthek.com](http://www.docuthek.com)

### Certified to SIL and PL



For systems up to SIL 3 pursuant to EN 61508 and PL e pursuant to ISO 13849. See page 122 (Safety-specific characteristic values for SIL and PL).

### EU certified



- 2014/35/EU (LVD), Low Voltage Directive
- 2014/30/EU (EMC), Electromagnetic Compatibility Directive
- (EU) 2016/426 (GAR), Gas Appliances Regulation
- EN 13611:2015+AC:2016
- EN 1854:2010, class S

### FM approved



Factory Mutual (FM) Research Class: 7610 “Combustion Safeguards and Flame Sensing Systems”. Designed for applications pursuant to NFPA 86.

[www.approvalguide.com](http://www.approvalguide.com)

### Eurasian Customs Union



The product BCU 480 meets the technical specifications of the Eurasian Customs Union.

## 3 Function

### 3.1 Part designations

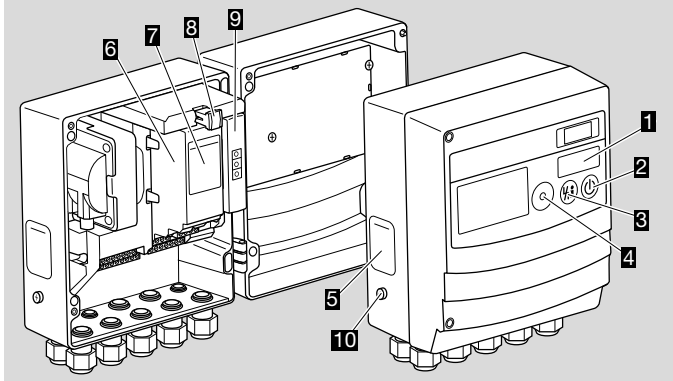

<b>1</b>	To display the program status or fault message and, in conjunction with the Reset/Information button, to display the flame signal and the fault history or to view and set device parameters.
<b>2</b>	To switch the control unit on or off
<b>3</b>	To reset the control unit to its starting position in the event of a fault. System faults (internal errors) can only be acknowledged using this button.
<b>4</b>	Connection for opto-adaptor
<b>5</b>	BCU type label
<b>6</b>	Power module, replaceable
<b>7</b>	Power module type label
<b>8</b>	Parameter chip card (PCC), replaceable
<b>9</b>	Bus module, replaceable
<b>10</b>	M5 screw terminal for burner ground

There are two control keys for the control unit:

	Use the ON/OFF key to switch the control unit on or off.
--	--



The control unit is reset to its starting position in the event of a fault using the Reset/Information button.

During operation, the LED display **1** shows the program status. The flame signal intensity, the fault history and the parameters can be called up on the display by repeatedly pressing the Reset/Information button (for 1 s). The parameter display is ended 60 seconds after the last time the button is pressed or by switching off the BCU. When the BCU is switched off, -- is displayed. The parameters cannot be scanned when the BCU is switched off or when a fault/warning is displayed.

Display	Information
<i>Fl</i>	Burner 1 flame signal intensity
<i>H0</i> to <i>H9</i>	Last event message to tenth to last event message
<i>001</i> to <i>999</i>	Parameter 001 to parameter 999

### 3.2 Connection diagram

Electrical connection, see page 107 (Electrical connection)

Explanation of symbols, see page 126 (Legend)

#### 3.2.1 BCU 480..E1/LM 400..F3..E1 with ionization control in double-electrode operation

Alternative flame control, see page 22 (Flame control)

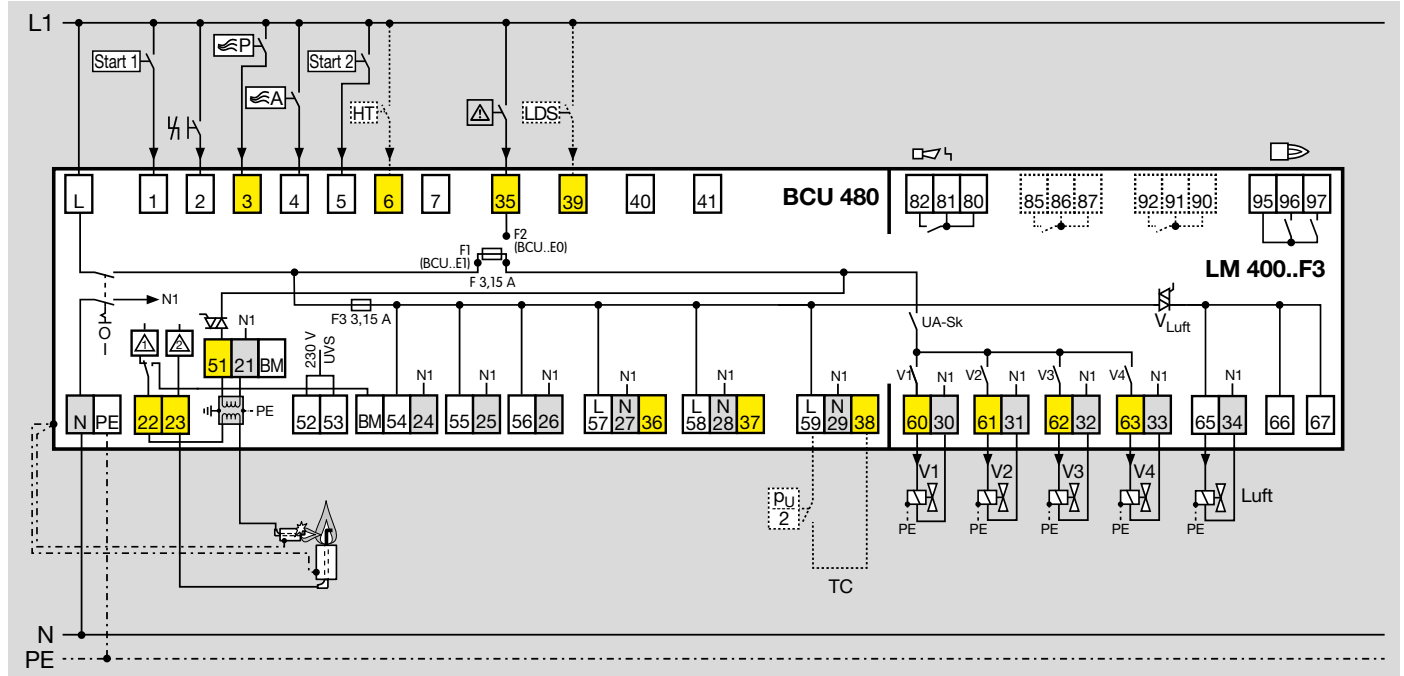

### 3.2.2 BCU 480..P3..E1/LM 400..F3..E1 with industrial plug for ionization control in double-electrode operation

Alternative flame control, see page 22 (Flame control)

Electrical connection, see page 107 (Electrical connection)

Explanation of symbols, see page 126 (Legend)

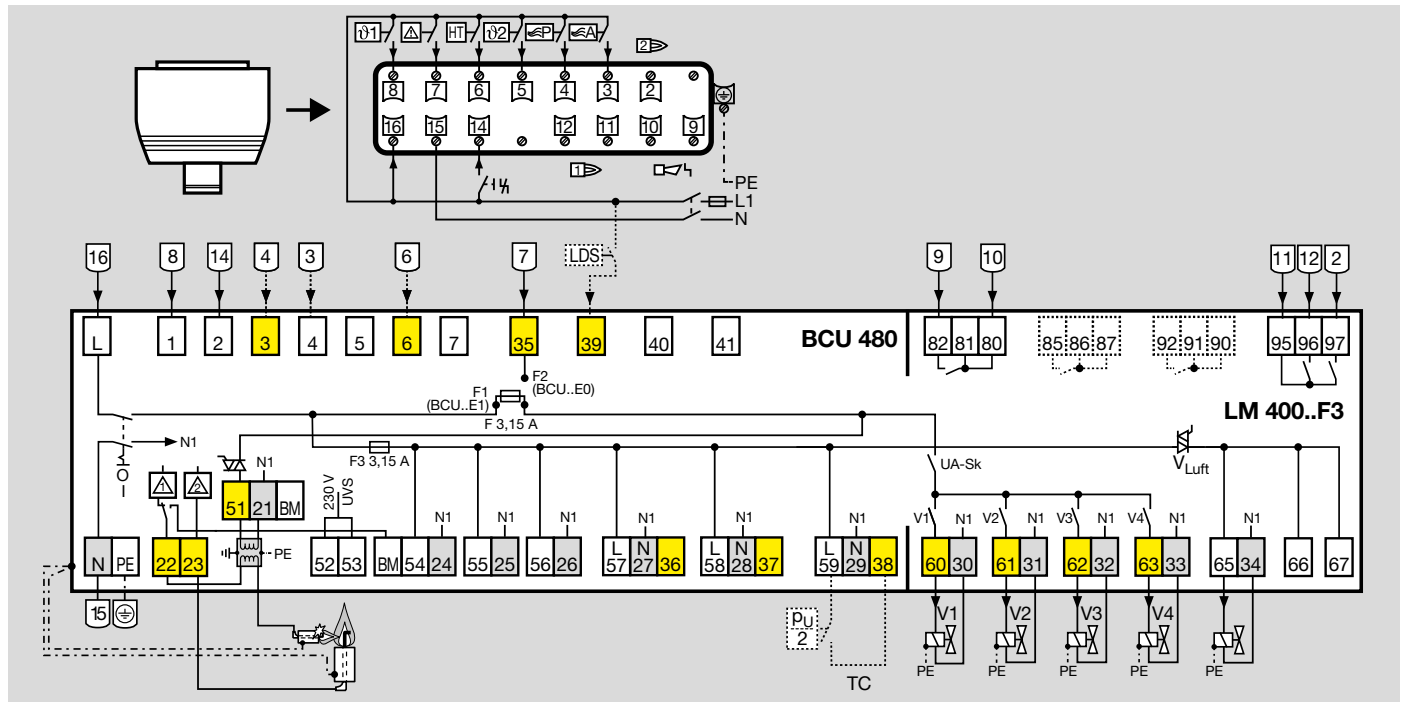

### 3.2.3 Flame control

In the case of UV control, use Elster UV sensors for intermittent operation (UVS 5, 10) or flame detectors for continuous operation (UVC 1).

#### Pilot burner = double-electrode operation/main burner = ionization

Pilot burner in double-electrode operation

Ionization control for main burner

Parameter I004 = 0.

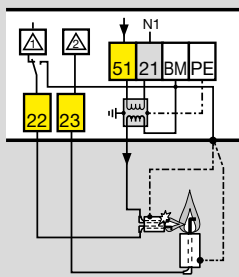

#### Pilot burner = single-electrode operation/main burner = ionization

Parameter I004 = 0.

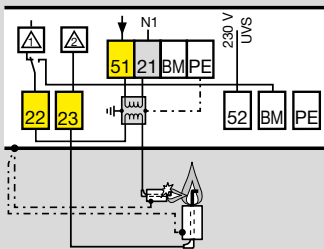

#### Pilot burner = single-electrode operation/main burner = UVS

Parameter A001  $\geq 5 \mu\text{A}$ .

Parameter I004 = 3.

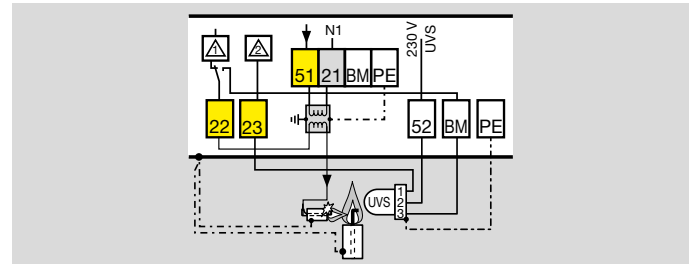

#### Pilot burner = single-electrode operation/main burner = UVC

Parameter I004 = 4.

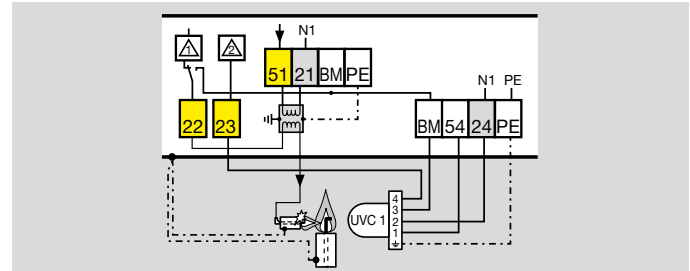

**Pilot burner = UVS/main burner = ionization**

Parameter A002  $\geq 5 \mu\text{A}$ .

Parameter I004 = 5.

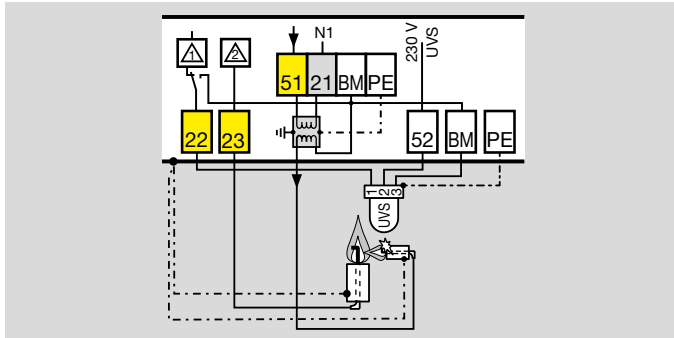

**Pilot burner = UVC/main burner = ionization**

Parameter I004 = 7.

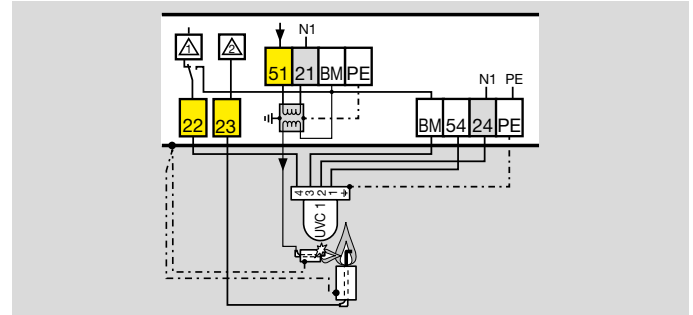

**Pilot burner = UVC/main burner = UVC**

Parameter I004 = 2.

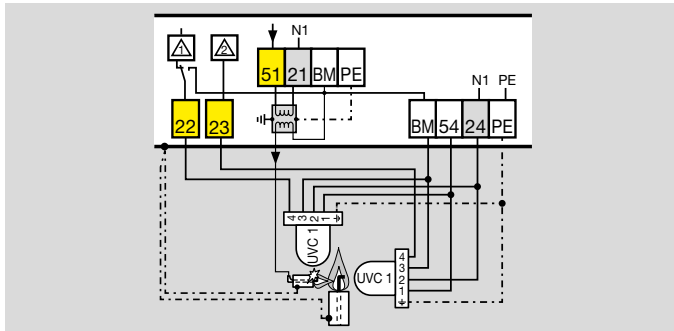

### 3.2.4 Assignment of connection terminals

#### Control input (AC mains voltage)

Terminal	Designation	Function
1	Start-up signal 1	Signal applied: heating (pilot burner) start; no signal: heating stop
2	Remote reset	Input for external signal (button) to reset the unit after a fault lock-out. System faults (internal errors) can only be acknowledged using this button.
3	External purge air	If there is an active signal, the BCU opens the air actuator regardless of the status of the other inputs.
4	External air valve control	External air valve control with an active signal, e.g. to supply air to the combustion chamber for cooling. Controlled air flow is only possible in standby with deactivated start-up signal. As soon as heating operation is started (start-up signal at terminal 1), the function is interrupted.
5	Start-up signal 2	Signal applied: heating (main burner) start; no signal: heating stop
6	High temperature operation feedback	High temperature operation feedback input. When the input is activated, the BCU operates without evaluating the flame signal. The safety function of the device's internal flame control system is deactivated.
35	Controller enable/Emergency stop	Connection for higher-level safety devices and interlocks (e.g. emergency stop)
39	LDS query	Feedback signal of the control element position for ignition capacity. As soon as a signal is present, the BCU completes a burner start, restart or start-up attempt.

#### Safety circuit input (AC mains voltage)

Terminal	Designation	Function
40	Feedback from actuator	Feedback input for ignition position
41	Feedback from actuator	Feedback input for maximum capacity

#### Input ( $\mu$ A )

Terminal	Designation	Function
22	Flame signal 1 (pilot burner)	Connection for flame rod/UV sensor
23	Flame signal 2 (main burner)	Connection for flame rod/UV sensor

#### Output (AC mains voltage), supply voltage

Terminal	Designation	Function
52	UV sensor	Voltage supply for UV sensor UVS for burner 1 (pilot burner)
53	UV sensor	Voltage supply for UV sensor UVS for burner 2 (main burner)

#### Supply voltage

Terminal	Designation	Function
54, 24	UV sensor for continuous operation	Voltage supply for UV sensor UVC 1

## Function

Terminal	Designation	Function
55, 25 56, 26 57, 27 58, 28	Active mains voltage	Voltage supply for actuators and sensors

### Voltage supply + safety circuit input (AC mains voltage)

Terminal	Designation	Function
59, 29	Valve proving system	Connection for the sensor of the valve proving system (pressure switch for tightness test or POC switch for checking the closed position)

### Valve outputs (AC mains voltage)

Terminal	Designation	Function
60, 30	Gas valve V1	Connection for gas valve V1
61, 31	Gas valve V2	Connection for gas valve V2
62, 32	Gas valve V3	Connection for gas valve V3
63, 33	Gas valve V4	Connection for gas valve V4

### Outputs (AC mains voltage)

Terminal	Designation	Function
<b>LM..F1:</b> 64, 65, 66, 67	Capacity control	Connections for capacity control using an actuator
<b>LM..F3:</b> 65, 66, 67	Air valve control	Connections for air valves

### Floating contact

Terminal	Designation	Function
80, 81, 82	Fault signal	Contact between terminals 80/81 and 82 closes in the event of a BCU fault lock-out.
95, 96, 97	Operation	Contact between terminals 95 and 96 closes once the operating signal has been received from burner 1. Contact between terminals 95 and 97 closes once the operating signal has been received from burner 2.
85, 86, 87	Parameter-dependent function	Contact can be adjusted depending on parameter I054
90, 91, 92	Parameter-dependent function	Contact can be adjusted depending on parameter I051

### 3.3 Program sequence

	Switch on BCU 480
	▼
	In the event of fault signal: reset
	▼
00	Safety interlocks Start-up position/Standby
	▼
00	Flame simulation check (if parameter A003 = 0)
	▼
P0	External actuation of the air valve for purging
	▼
R0	External actuation of the air valve for cooling
	▼
01	Start-up with start-up signal (start 1)
	▼
01	Wait until the min. pause has elapsed (parameter A062)
	▼
01	Flame simulation check (if parameter A003 = 1)
	▼
02	Safety time 1 $t_{SA1}$ (A094) running, ignition in process, valves for 1 <sup>st</sup> gas stage open and min. operating time starts to elapse (A061)
	▼
02	If no flame detected: max. 3 start-up attempts (A007) or fault lock-out
	▼
03	Flame proving period 1 $t_{FS1}$ running (A095)
	▼
03	In the event of flame failure: fault lock-out
	▼
04	Pilot burner operation signalling contact closes, valve for 2 <sup>nd</sup> gas stage opens and min. operating time $t_B$ starts to elapse (A061)
	▼
04	In the event of flame failure: restart or fault lock-out
	▼
R4	External actuation of the air valve for capacity control

	▼
05	Main burner start-up with start-up signal (start 2)
	▼
05	Wait until the min. pause has elapsed (parameter A062)
	▼
05	Flame simulation check (if parameter A003 = 1)
	▼
06	Safety time 2 $t_{SA2}$ (A096) running, ignition in process, valves for 2 <sup>nd</sup> gas stage open and min. operating time starts to elapse (A061)
	▼
06	If no flame detected: max. 3 start-up attempts (A008) or fault lock-out
	▼
07	Flame proving period 2 $t_{FS2}$ running (A097)
	▼
07	In the event of flame failure: fault lock-out
	▼
08	Main burner operation signalling contact closes
	▼
08	In the event of flame failure: restart or fault lock-out
	▼
08	External actuation of the air valve for capacity control
	▼
08	Controlled shut-down via start-up signal
	▼
00	If min. operating time $t_B$ has elapsed: operation signalling contact opens, gas valves close and min. operating time starts to elapse (A061)

## 4 Air control

A central protective system such as the FCU 500 takes over air control. It monitors the static air pressure as well as the air volume required for pre-purge, start-up and after the furnace has been shut down. The air actuators (BCU with LM..F3 =

actuator IC 40, BCU with LM..F3 = valve) are actuated for this purpose by the capacity control system of the BCU. After being enabled by the protective system, the BCU can start the burners. The capacity is controlled during operation by an external temperature control system.

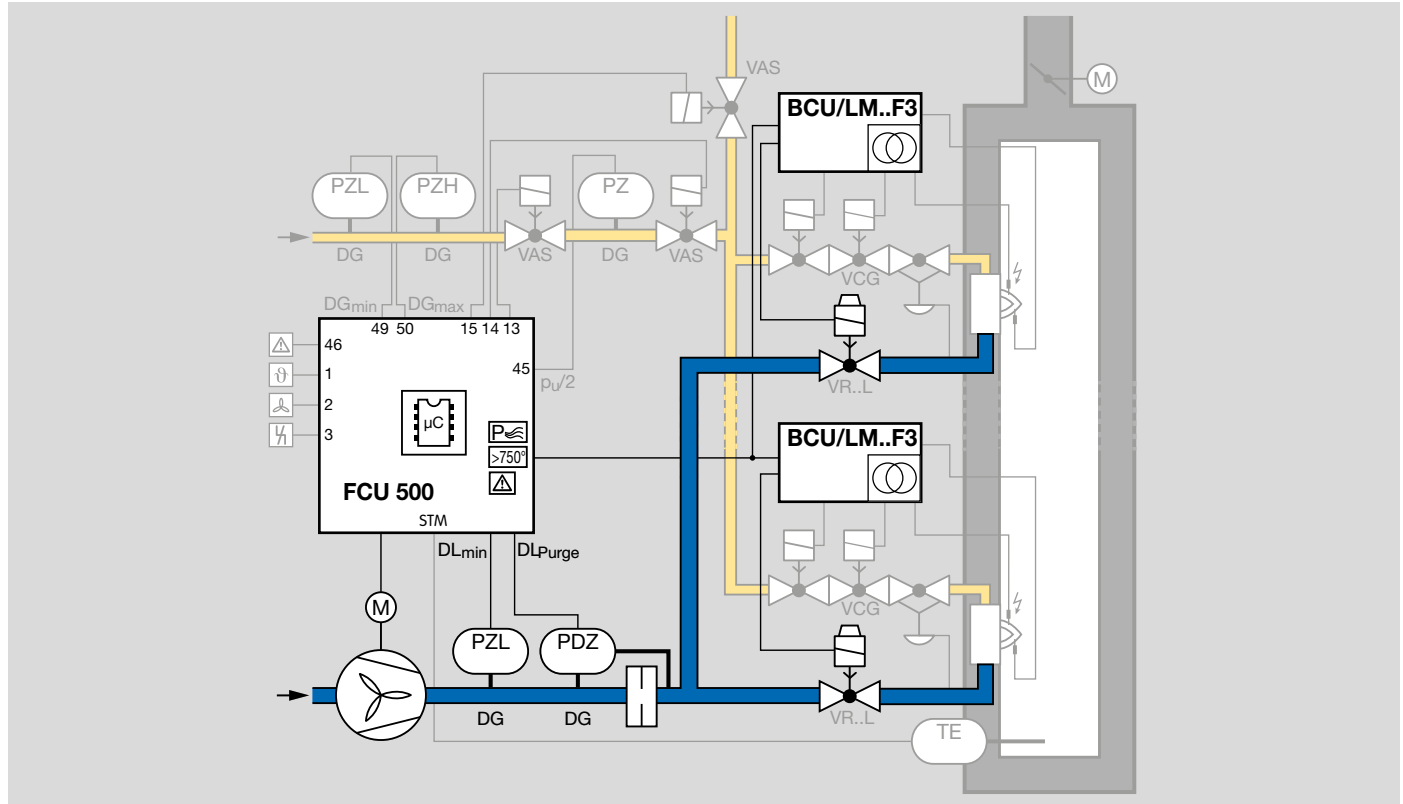

## 4.1 Capacity control

### 4.1.1 BCU..F1

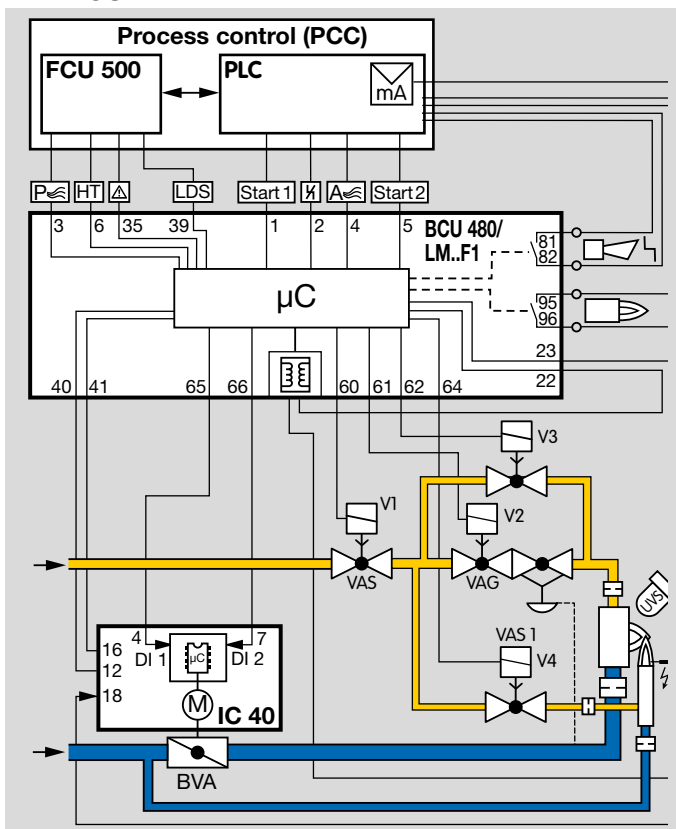

The BCU with LM..F1 activates a control element via the outputs for capacity control (terminals 64 to 67) for purging, cooling or starting the burner. This control element moves to the required position for the relevant operating situation.

As soon as there is a purge signal at terminal 3 of BCU, the control element is activated by the outputs for capacity control to approach the position for pre-purge. The protective system (FCU 500) starts the pre-purge time if there is adequate air flow. After the elapse of the pre-purge time, the control element moves to the ignition position. Once the protective system (terminal 35, safety interlocks) has issued the enable signal, the pilot and main burners can be started by the start-up signals at terminals 1 and 5. The control element can be activated to control the burner's capacity dependent on parameters A048 and A049.

### Modulating control

Parameter I020 = 2, A048 = 2

After the operating signal has been received from the burner, the BCU issues the controller enable signal via the output at terminals 65 and 66. Access to the control element is thus transferred to an external temperature controller. The temperature controller controls the burner capacity (air volume) on the basis of the required temperature.

Detailed information about parameter I020, see page 93 (Air actuator).

### Staged control

A048 = 0, 1 or 2

Depending on parameters A048 and A049, the control element may be activated either by the program or externally via the input at terminal 4, see also page 82 (Air actuator control) and page 83 (Air actuator on start-up can be activated externally).

## 4.1.2 BCU..F3

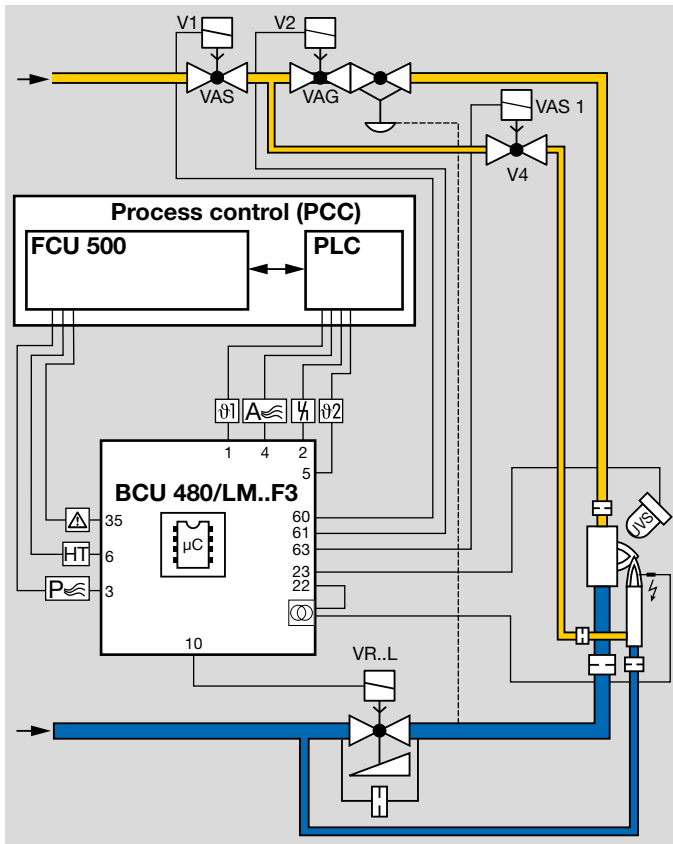

The BCU with LM..F3 activates an air valve for purging, cooling or starting the burner. The required air capacity is released by the air valve.

As soon as there is a purge signal at terminal 3 of BCU..F3, the air valve is activated by the output at terminal 65. The protective system (FCU 500) starts the pre-purge time if

there is adequate air flow. After the elapse of the pre-purge time, the air valve closes for ignition. Once the protective system (terminal 35, safety interlocks) has issued the enable signal, the burner can be started by the start-up signal at terminal 1. The gas valves for the 1<sup>st</sup> stage are opened and the burner is ignited (on the BCU..C1 after a successful valve check). After the operating signal has been received from the burner, the gas valve for the 2<sup>nd</sup> stage opens.

**Staged control**

A048 = 0, 1 or 2

Depending on parameters A048 and A049, the control element may be activated either by the program or externally via the input at terminal 4, see also page 82 (Air actuator control) and page 83 (Air actuator on start-up can be activated externally).

## 5 Valve proving system

The BCU 500..C1 is fitted with an integrated valve proving system. This allows either the tightness of the gas solenoid valves and the pipework between them to be checked or the closed position of a solenoid valve to be checked.

Once the test has been carried out successfully, the burner enable signal is issued.

### 5.1 Tightness control

The aim of the tightness control is to identify an inadmissible leak on one of the gas solenoid valves and to prevent burner start. Gas solenoid valves V1 and V2 are tested as is the pipework between the valves.

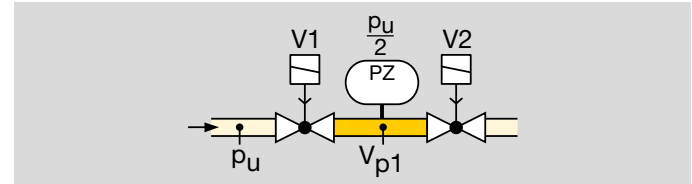

💡 European standards EN 746-2 and EN 676 stipulate tightness controls for capacities over 1200 kW (NF-PA 86: from 117 kW or 400,000 Btu/h).

💡 The tightness control function satisfies the requirements of EN 1643 (Valve proving systems for automatic shut-off valves for gas burners and gas appliances).

### 5.1.1 Test instant

Depending on the parameter setting, the tightness control checks the tightness of the pipework and the gas solenoid valves before each start-up and/or after each shut-down of the burner, see page 85 (Valve proving system).

The gas line is always safeguarded by a gas solenoid valve during this check.

#### Before burner start-up

The valve check is started when the start-up signal is present at terminal 1. The BCU checks the tightness of the gas solenoid valves and the pipework between the valves. The gas line is always safeguarded by a gas solenoid valve during this check. The pilot burner is ignited when pre-purge is ended and the tightness has been checked successfully.

#### After burner shut-down

After the burner has been shut down, the BCU checks the tightness of the gas solenoid valves and the pipework between them. Once the test has been carried out successfully, the next burner start is enabled. The BCU immediately conducts a tightness test if mains voltage is available or if it is reset after a fault lock-out.

An additional bypass/relief valve must be installed in gas sections with an air/gas ratio control. This ensures that the test volume  $V_{p1}$  can be vented during the tightness test with the air/gas ratio control closed.

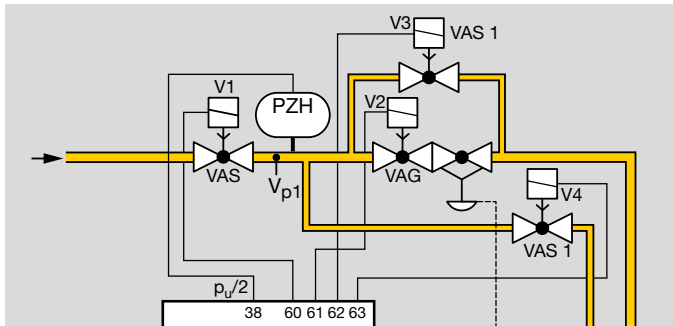

5.1.2 Program sequence

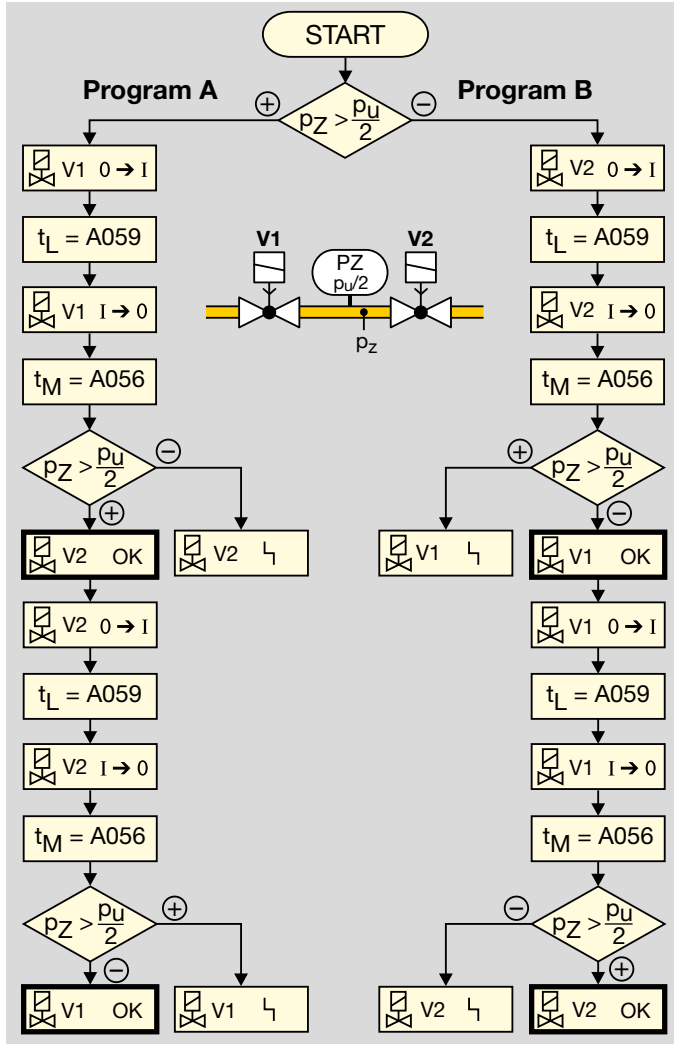

The tightness test starts by checking the external pressure switch.

If pressure  $p_z > p_u/2$ , program A starts.

If pressure  $p_z < p_u/2$ , program B starts.

**Program A**

Valve V1 opens for the opening time  $t_L$  set in parameter A059. V1 closes again. During the measurement time  $t_M$ , the tightness control checks the pressure  $p_z$  between the valves.

If pressure  $p_z$  is less than half the inlet pressure  $p_u/2$ , valve V2 is leaking.

If pressure  $p_z$  is greater than half the inlet pressure  $p_u/2$ , valve V2 is tight. Valve V2 is opened for the set opening time  $t_L$ . V2 closes again.

During the measurement time  $t_M$ , the tightness control checks the pressure  $p_z$  between the valves.

If pressure  $p_z$  is greater than half the inlet pressure  $p_u/2$ , valve V1 is leaking.

If pressure  $p_z$  is less than half the inlet pressure  $p_u/2$ , valve V1 is tight.

The tightness test can only be performed if pressure  $p_d$  downstream of V2 is around atmospheric pressure and the volume downstream of V2 is at least  $5 \times$  higher than the volume between the valves.

**Program B**

Valve V2 opens for the set opening time  $t_L$ . V2 closes again. During the measurement time  $t_M$ , the tightness control checks the pressure  $p_z$  between the valves.

If pressure  $p_z > p_u/2$ , valve V1 is leaking. If pressure  $p_z < p_u/2$ , valve V1 is tight. Valve V1 is opened for the set opening time  $t_L$ . V1 closes again.

## Valve proving system

---

During the measurement time  $t^M$ , the tightness control checks the pressure  $p_Z$  between the valves.

If pressure  $p_Z < p_U/2$ , valve V2 is leaking.

If pressure  $p_Z > p_U/2$ , valve V2 is tight.

The tightness test can only be performed if pressure  $p_d$  downstream of V2 is around atmospheric pressure and the volume downstream of V2 is at least  $5 \times$  higher than the volume between the valves.

### 5.1.3 Test period $t_p$

Depending on the burner capacity, the tightness of the gas solenoid valves must be checked in accordance with the relevant application standard, e.g. EN 676, EN 746, NF-PA 85 and NFPA 86.

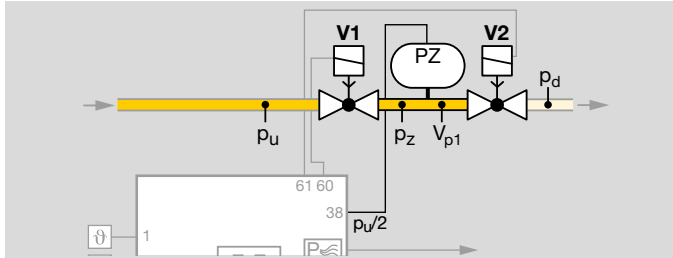

The test period  $t_p$  is calculated from:

- Opening times  $t_L$  for V1 and V2,
- Measurement times  $t_M$  for V1 and V2.

$$t_p \text{ [s]} = 2 \times t_L + 2 \times t_M$$

### 5.1.4 Opening time $t_L$

Standard EN 1643:2000 allows a maximum opening time of 3 s for the tightness test if the main gas valves are actuated directly. If gas can flow into the combustion chamber when a valve is opened, the gas volume must not exceed 0.083% of the maximum flow rate.

### 5.1.5 Measurement time $t_M$

The sensitivity of the tightness control in the BCU can be adjusted for each individual system by adapting the measurement time  $t_M$ . The longer the measurement time  $t_M$ , the greater the sensitivity of the tightness control. The measurement time is set using parameter A056 to a value between 3 and 3600 s, see page 86 (Measurement time for  $V_{p1}$ ).

The required measurement time  $t_M$  is calculated from:

Inlet pressure  $p_u$  [mbar]

Leakage rate  $Q_L$  [l/h]

Test volume  $V_{p1}$  [l]

maximum leakage rate  $Q_L$  is 0.1% of the maximum flow rate  $Q_{(N)max}$ . [m<sup>3</sup>/h].

$$\text{Leakage rate } Q_L \text{ [l/h]} = Q_{(N)max} \text{ [m}^3\text{/h]} \times 0.1 \%$$

### For one test volume $V_{p1}$ between 2 gas solenoid valves

Adjustable using parameter A056

$$t_M \text{ [s]} = \left( \frac{2 \times p_u \times V_{p1}}{Q_L} \right)$$

### For a large test volume $V_{p1}$ with reduced testing time

Adjustable using parameter A056

$$t_M \text{ [s]} = \left( \frac{0,9 \times p_u \times V_{p1}}{Q_L} \right)$$

Conversion into US units, see [www.adlatus.org](http://www.adlatus.org)

### Leakage rate

The BCU tightness control makes it possible to check a specific leakage rate  $Q_L$ . Within the European Union, the

### Test volume $V_{p1}$

Test volume  $V_{p1}$  is calculated from the valve volume  $V_V$ , added to the volume of the pipe  $V_R$  for each additional metre in length  $L$ .

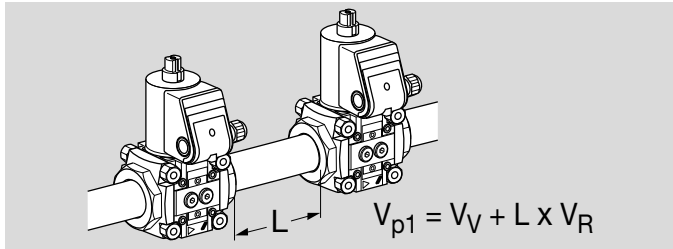

Valves		Pipe	
Type	Volume $V_V$ [l]	DN	Volume per metre $V_R$ [l/m]
VAS 1	0.08	10	0.1
VAS 2	0.32	15	0.2
VAS 3	0.68	20	0.3
VAS 6	1.37	25	0.5
VAS 7	2.04	40	1.3
VAS 8	3.34	50	2
VAS 9	5.41	65	3.3
VG 10	0.01	80	5
VG 15	0.07	100	7.9
VG 20	0.12	125	12.3
VG 25	0.2	150	17.7
VG 40/VK 40	0.7	200	31.4
VG 50/VK 50	1.2	250	49
VG 65/VK 65	2		
VG 80/VK 80	4		
VK 100	8.3		
VK 125	13.6		
VK 150	20		
VK 200	42		

Valves		Pipe	
Type	Volume $V_V$ [l]	DN	Volume per metre $V_R$ [l/m]
VK 250	66		

The measurement time required for the test volume  $V_{p1}$  must be set on the basis of the calculation using parameter A056.

## Calculation examples

2 valves VAS 665,

distance  $L = 9.5 \text{ m}$ ,

inlet pressure  $p_U = 50 \text{ mbar}$ ,

max. flow rate  $Q_{(N)\text{max.}} = 200 \text{ m}^3/\text{h}$ .

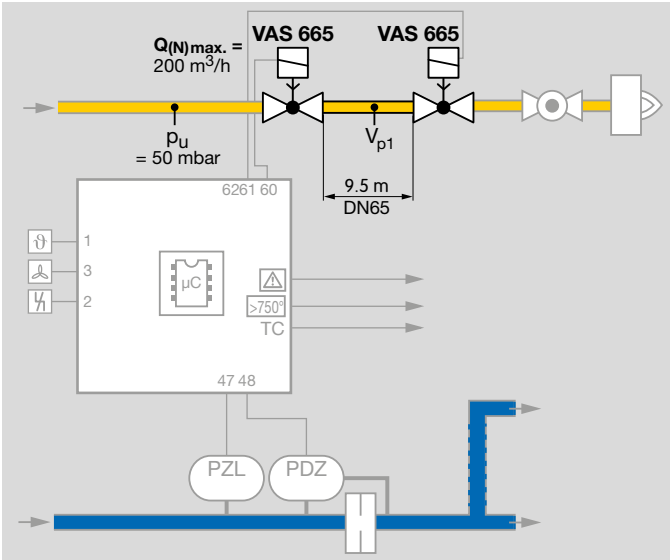

Leakage rate  $Q_L = 200 \text{ m}^3/\text{h} \times 0.1 \% = 200 \text{ l/h}$

Test volume  $V_{p1} = 1.1 \text{ l} + 9.5 \text{ m} \times 3.3 \text{ l/m} = 32.45 \text{ l}$

Measurement time for test volume  $V_{p1}$ :

$$t_M [\text{s}] = \left( \frac{2 \times 50 \text{ mbar} \times 32.45 \text{ l}}{200 \text{ l/h}} \right) = 16.23 \text{ s}$$

Set the next highest value (20 s) using parameter 56, see page 86 (Measurement time for  $V_{p1}$ ).

### 5.2 Proof of closure function

The proof of closure function monitors the function of a gas solenoid valve (V1, V2, V3 or V4). A limit switch on the gas solenoid valve signals the closed position of the valve to the BCU for this purpose. Parameter I073 must be set to 3 in this case, see page 100 (Function of input 38).

Parameter A101, A102 or A103 is used to define the valve from which the signal for the closed position must be received:

A101, A102 or A103 = 48 (V1), 49 (V2), 50 (V3), 51 (V4), see page 89 (Sensors).

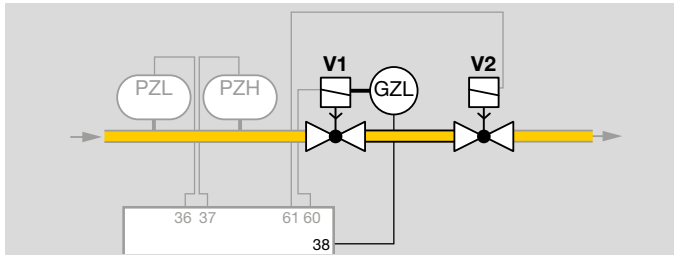

By checking the closed position using the proof of closure function, the BCU complies with the requirements of NFPA 85 (Boiler and Combustion Systems Hazards Code) and NFPA 86 (Standard for Ovens and Furnaces).

#### Program sequence

When the start-up signal is received at terminal 1, the BCU checks that the valve is in its closed position using the POC switch. If a signal is not received at terminal 38 from the POC switch after a timeout time of 10 s (valve is closed), the BCU performs a fault lock-out with fault message “E c1”.

As soon as the BCU has opened the valve, it queries the open position of the valve via the POC switch. If a signal is still being received at terminal 38 from the POC switch after

a timeout time of 10 s, the BCU performs a fault lock-out with fault message “E c8”.

## 6 BCSoft

BCSoft is an engineering tool for PCs with a Windows operating system. BCSoft (from version 4.x.x) makes it possible to set device parameters in order to adjust them to the specific application. BCSoft logs and archives the device parameters. In addition, BCSoft offers further functions. In conjunction with Manual mode, the process values overview provides commissioning support in order to facilitate the commissioning process. In the event of faults or service interventions, details on troubleshooting can be derived from the device statistics and the fault history.

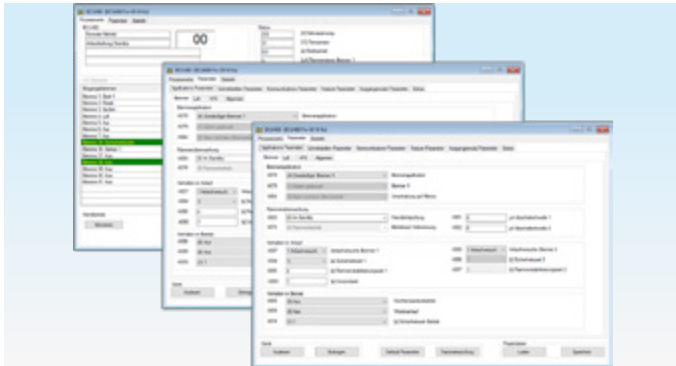

The current version of the engineering tool BCSoft4 is available at [www.docuthek.com](http://www.docuthek.com).

In addition to the engineering tool BCSoft, an opto-adapter with USB connection is required for data transfer between the PC and BCU. If the burner control unit BCU is operated in conjunction with the bus module BCM 400, communication via Ethernet is possible.

BCSoft4 and opto-adapter PCO 200, see page 110 (Accessories).

## 7 Fieldbus communication

PROFIBUS DP, PROFINET and EtherNet/IP are manufacturer-independent, open standards for industrial network communication. They cover the requirements for automation technology (manufacturing automation, process automation, drive applications without functional safety). They are bus variants for fieldbus communication optimized for speed and low connection costs.

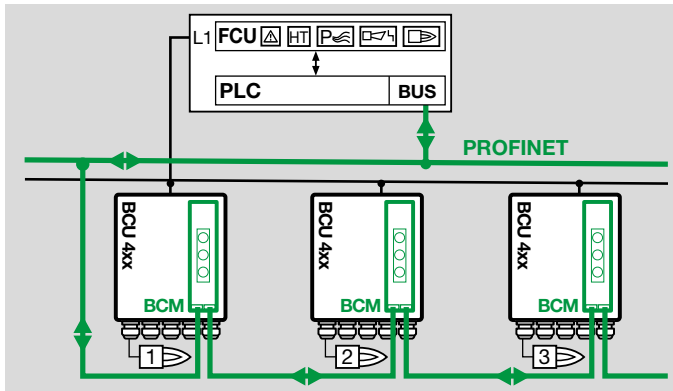

The basic function of fieldbus communication is the exchange of process and required data between a controller (e.g. a PLC) and several distributed devices (e.g. BCM with BCU 480).

The signals from the devices are read into the controller cyclically. There, they are processed and are then output to the devices again.

## 7.1 BCU and bus module BCM

The optional bus module BCM 400 is required to integrate the BCU in a standardized fieldbus system (PROFIBUS, PROFINET or EtherNet/IP).

Control signals (for start, reset and air actuator control, for example), signal states from the device inputs and outputs and information about the device status (operating states, flame signal and current program step), warnings and faults can be transferred simultaneously via the bus module between the BCU and PLC.

The bus module for PROFIBUS BCM 400..B1 has a 9-pin D-Sub connection socket on the front, while the bus modules for PROFINET BCM 400..B2 and EtherNet/IP BCM 400..B3 have two RJ45 connection sockets on the front for connection to the fieldbus. The RJ45 connection sockets are combined with an internal 2-port switch. This allows the BCM 400 together with the BCU to be integrated in various network topologies (star, tree or line topology). Requirements such as Auto Negotiation and Auto Crossover are satisfied.



Safety-related signals and interlocks (e.g. safety interlock) must be wired independently of the fieldbus communication direct between the BCU and the protective system (e.g. FCU).

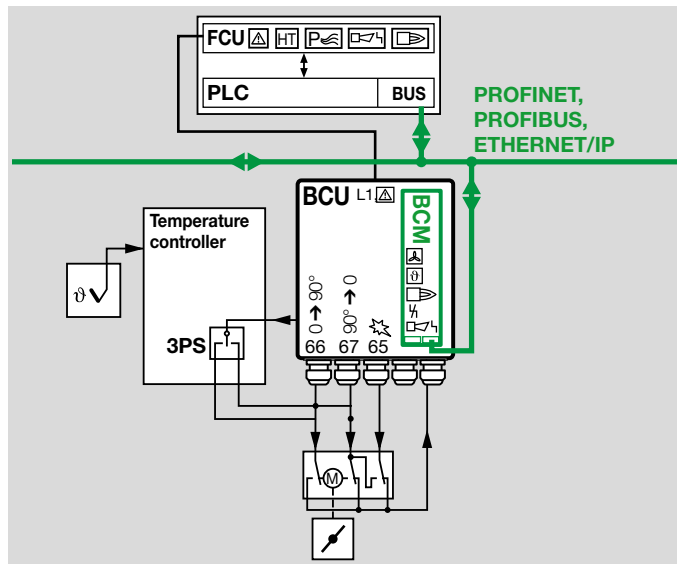

All network components which connect the automation system and the field devices must be certified for the relevant fieldbus use.

For information on planning and the structure of a network and the components to be used (e.g. cables, lines and switches) for PROFINET and PROFIBUS, see [www.profinet.com](http://www.profinet.com), for EtherNet/IP, see [www.odva.org](http://www.odva.org).

### 7.2 Configuration, planning

Before commissioning, the bus module must be configured for data exchange with the fieldbus system using an engineering tool or BCSOFT.

To do so, fieldbus communication must be enabled on the control unit with connected bus module BCM and the code switches on the BCM set, see also page 90 (Fieldbus communication).

#### 7.2.1 Device master data file (GSD), electronic data sheet (EDS)

The technical properties of a device are described by the manufacturer for PROFIBUS and PROFINET in a device master data file (GSD file) or for EtherNet/IP in an electronic data sheet (EDS). The GSD/EDS file is required to integrate the device (BCU) in the configuration of the PLC. The GSD/EDS file contains the device image, the communications properties and all fault messages from the device in text form which are important for configuring the PROFINET network and the data exchange. Modules defined in the GSD/EDS file may be selected for configuration to integrate the device. The GSD/EDS file for the bus module can be obtained from [www.docuthek.com](http://www.docuthek.com). The steps required to integrate the file are described in the instructions for the engineering tool for your automation system.

### 7.3 PROFINET, EtherNet/IP

In addition to cyclic data exchange, the PROFINET and EtherNet/IP fieldbus systems also provide acyclic data exchange for events which are not constantly repeated, such as sending device statistics. In the event that the bus communication is faulty or interrupted and during initialization of the bus communication after switching on, the digital signals are interpreted as “0”.

#### 7.3.1 Modules for process data

All modules required for data exchange between the PLC and the burner control unit BCU are shown in the following table.

Module (PROFINET)	Slot
Inputs (BCU → PLC)	1
Outputs (PLC → BCU)	1
Burner 1 flame signal	2
Burner 2 flame signal	3
Status signal	4
Fault and warning signals	5
Remaining times	6
Temperature	7
Input information (via terminal and bus)	9
Output information (via terminal and bus)	10

### Inputs/Outputs

The digital input and output signals from the burner control unit BCU are included in this module.

#### Input bytes (BCU → PLC)

The input bytes describe the digital signals which are transferred from the BCU to the digital inputs of the PLC. The digital signals take up 3 bytes (24 bits).

Bit	Byte n	Byte n+1	Byte n+2	Format
0	Burner 1 operating signal	Free	Flameless operation	BOOL
1	Burner 2 operating signal	Free	Free	BOOL
2	BCU system fault	Air ON	Free	BOOL
3	Fault lock-out	Pre-purge ON	Free	BOOL
4	Safety shut-down	HT ON	Free	BOOL
5	Warning	Ready for operation	Free	BOOL
6	ON	Burner 1 flame signal	Free	BOOL
7	Manual mode	Burner 2 flame signal	Free	BOOL

#### Output bytes (PLC → BCU)

The output bytes describe the digital signals which are output by the PLC to the BCU. The digital signals to control the burner control unit BCU occupy 2 bytes (16 bits).

Terminals 1 to 41 (dependent on parameters I061 to I074) can be wired parallel to the bus communication. This allows the BCU to be controlled using the digital signals of the bus communication or the inputs at the terminals.

Bit	Byte n	Byte n+1	Format
0	Reset <sup>1)</sup>	Auxiliary gas	BOOL
1	Burner 1 start <sup>1)</sup>	Optional output	BOOL
2	External air ON <sup>1)</sup>	Cooling air valve	BOOL

Bit	Byte n	Byte n+1	Format
3	Pre-purge ON	Free	BOOL
4	Burner 2 start <sup>1)</sup>	Free	BOOL
5	Flameless mode ON <sup>2)</sup>	Free	BOOL
6	Free	Free	BOOL
7	Free	Free	BOOL

1) Terminals 1 to 41 (dependent on parameters I061 to I074) can be wired parallel to the bus communication.

2) Only with BCU 465 depending on the parameter settings.

### Burner 1 flame signal (BCU → PLC)

The flame signal for burner 1 is transferred from the BCU to the PLC as an analogue value using this module. The flame signal occupies one byte with values from 0 to 255 (= flame signal from 0 to 25.5  $\mu$ A).

Bit	Byte n	Data type	Format	Value
1	Burner 1 flame signal	Byte	DEC	0–255 <sup>1)</sup> (0–25.5 $\mu$ A)
2				
3				
4				
5				
6				
7				

<sup>1)</sup> See code tables “BusCommunication\_BCU4\_R2.xlsx” at [www.docuthek.com](http://www.docuthek.com).

### Burner 2 flame signal (BCU → PLC)

The flame signal for burner 2 is transferred from the BCU to the PLC as an analogue value using this module. The flame signal occupies one byte with values from 0 to 255 (= flame signal from 0 to 25.5  $\mu$ A).

Bit	Byte n	Data type	Format	Value
1	Burner 2 flame signal	Byte	DEC	0–255 (0–25.5 $\mu$ A)
2				
3				
4				
5				
6				
7				

<sup>1)</sup> See code tables “BusCommunication\_BCU4\_R2.xlsx” at [www.docuthek.com](http://www.docuthek.com).

### Status signal (BCU → PLC)

This module transfers the status signals from the BCU to the PLC. The status signals occupy one byte (0 to 255). Every status signal is allocated a code. The allocation is

described in the code table “BusCommunication\_BCU4\_R2.xlsx”.

Bit	Byte n	Data type	Format	Value
1	Status messages	Byte	DEC	0–255
2				
3				
4				
5				
6				
7				

<sup>1)</sup> See code tables “BusCommunication\_BCU4\_R2.xlsx” at [www.docuthek.com](http://www.docuthek.com).

### Fault and warning signals (BCU → PLC)

The fault and warning signals are transferred from the BCU to the PLC using this module. The fault and warning signals each occupy one word.

The same allocation table applies to the fault signals and the warning signals.

Bit	Byte n	Byte n+1	Data type	Format	Value
1	Fault signals		Word	DEC	0–65535 <sup>1)</sup>
2					
3					
4					
5					
6					
7					

Bit	Byte n+2	Byte n+3	Data type	Format	Value
1	Warning signals		Word	DEC	0–65535 <sup>1)</sup>
2					
3					
4					
5					
6					
7					

<sup>1)</sup> See code tables “BusCommunication\_BCU4\_R2.xlsx” at [www.docuthek.com](http://www.docuthek.com).

### Remaining times (BCU → PLC)

This module transfers the remaining times of various processes from the BCU to the PLC. The remaining time occupies one word.

Bit	Byte n	Byte n+1	Data type	Format	Value
1	Remaining times		Word	DEC	0–6554 (0–6554 s)
2					
3					
4					
5					
6					
7					

### Temperature (BCU → PLC)

This module transfers the internal device temperature. The temperature occupies one word.

Bit	Byte n	Byte n+1	Data type	Format	Value
1	Temperature		Word	DEC	0–6554 (0–6554 K)
2					
3					
4					
5					
6					
7					

### BCU input information (BCU → PLC)

This module transfers the signal states of the digital inputs on the BCU to the PLC.

Bit	Transfer via					Format
	Input terminals		K-SafetyLink	NFS bus		
	Byte n	Byte n+1	Byte n+2	Byte n+3	Byte n+4	
0	Terminal 1	Terminal 36	Safety interlocks (limits)	Reset	Auxiliary gas	BOOL
1	Terminal 2	Terminal 37	LDS	Burner 1 start	Optional output	BOOL
2	Terminal 3	Terminal 38	High temperature	Air	Cooling air valve	BOOL
3	Terminal 4	Terminal 39	Purge	Purge	Free	BOOL
4	Terminal 5	Terminal 40	Free	Burner 2 start	Free	BOOL
5	Terminal 6	Terminal 41	Free	Flameless operation	Free	BOOL
6	Terminal 7	Free	Free	Open control element	Free	BOOL
7	Terminal 35	Free	Free	Close control element	Free	BOOL

### BCU output information (BCU → PLC)

This module transfers the signal states of the digital outputs on the BCU (via output terminals and bus) to the PLC.

Bit	Byte n	Byte n+1	Byte n+2	Byte n+3	Byte n+4	Byte n+5	Format
0	Terminal 60	Terminals 80/81/82	Ready	Burner 1 operating signal	Control element to max. position	Flameless mode ON <sup>1)</sup>	BOOL
1	Terminal 61	Terminals 85/86/87	Purge ON	Burner 2 operating signal	Control element to closed position	Free	BOOL
2	Terminal 62	Terminals 90/91/92	Operating signal	BCU system fault	Air ON	Free	BOOL
3	Terminal 63	Terminals 95/96	Free	Fault lock-out	Purge ON	Free	BOOL
4	Terminal 64	Terminals 95/97	Free	Safety shut-down	HT ON	Free	BOOL
5	Terminal 65	Terminal 51	Free	Warning	Ready	Free	BOOL
6	Terminal 66	Free	Free	BCU ON	Burner 1 flame	Free	BOOL
7	Terminal 67	Free	Free	Manual mode	Burner 2 flame	Free	BOOL

<sup>1)</sup> Only with BCU 465 depending on the parameter settings.

### 7.3.2 Device parameters and statistics

With the help of acyclic communication between the PLC and BCU, it is possible to read information on parameters, statistics and fault history on an event basis (e.g. using system function block Siemens FSB 52 RDREC).

Description	PROFINET	EtherNet/IP	
	Index	Instance	Attribute
Parameter	1001	1	
Counter statistics	1002	2	
Fault/warning statistics	1003	3	1 (faults)
Fault/warning statistics	1003	3	2 (warnings)
Operator statistics, counters	1004	4	
Operator statistics, faults/warnings	1005	5	1 (faults)
Operator statistics, faults/warnings	1005	5	2 (warnings)
Event history	1006	6	
Power module statistics	1007	7	
Extreme values statistics	1008	8	
Time counter statistics	1009	9	
Operator statistics, extreme values	1010	10	
Operator statistics, time counters	1011	11	

The available data records differ in terms of their indexes (PROFINET) or instances (EtherNet/IP). The contents and description of the indexes/instances are described in the code table “BusCommunication\_BCU4\_R2.xlsx” (download from [www.docuthek.com](http://www.docuthek.com)).

## 7.4 PROFIBUS

Input bytes (BCU → master)					
Bit	Byte 0	Byte 1	Byte 2	Byte 3	Byte 4
0	Reset	Free	1)	2)	3)
1	Start 1	Free	1)	2)	3)
2	Air ON	Free	1)	2)	3)
3	Purge ON	Free	1)	2)	3)
4	Auxiliary gas/ Start 2	Free	1)	2)	3)
5	Free	Free	1)	2)	3)
6	Free	Free	1)	2)	3)
7	Free	Free	1)	2)	3)
	BCU 480 basic I/O				
BCU 480 standard I/O					

1) Program step/status (byte 0, bit 2 = 0) and fault message (byte 0, bit 2 = 1), see code table "BusCommunication\_BCU4\_R2.xlsx" at [www.docuthek.com](http://www.docuthek.com).

2) Burner 1 flame signal = 0–25.5 µA, 255 steps

3) Burner 2 flame signal = 0–25.5 µA, 255 steps

Output bytes (master → BCU)	
Bit	Byte 0
0	Reset
1	Start 1
2	Cooling
3	Purge
4	Start 2
5	Free
6	Free
7	Free

I/O bytes: the programmer can choose the data to be transferred.

	Inputs	Outputs
480 basic I/O	1 byte	1 byte
480 standard I/O	5 bytes	1 byte

Baud rate: up to 1500 kbit/s.

The max. range per segment depends on the baud rate:

Baud rate [kbit/s]	Range [m]
93.75	1200
187.5	1000
500	400
1500	200

The specified ranges can be increased by using repeaters. No more than three repeaters should be connected in series.

The specified ranges relate to bus cable type A (2-core, shielded and twisted), e.g.

Siemens, Order No. 6XV1830-0EH10, or  
Lapp cable unitronic, Order No. 2170-220T.

## 8 Program step/status

DISPLAY <sup>1)</sup>	Program step/status
00	Start-up position/Standby
R0	Cooling <sup>2)</sup>
P0	Pre-purge (external)
H0	Delay
01	Minimum pause time $t_{MP}$
R1	Pre-ventilation <sup>2)</sup>
d 0	"No flow" state check of low air pressure protection device
d 1	Low air pressure protection check
Rc	Approaching minimum capacity/closed position <sup>2)</sup>
Ro	Approaching maximum capacity
P0	Pre-purge
P1	Pre-purge
Ri	Approaching ignition capacity <sup>2)</sup>
HX	Delay (in program step X)
H2	Delay
tc	Valve check
02	Safety time 1
R2	Safety time 1 (with air)
03	Flame proving period 1 $t_{FS1}$
R3	Flame proving period 1 $t_{FS1}$ (with air)
04	Burner 1 operation/controller enable
R4	Burner 1 operation/controller enable (with air)
H4	Delay
05	Burner 2 waiting time
R5	Delay
06	Safety time 2
R6	Safety time 2 (with air)
07	Flame proving period 2
R7	Flame proving period 2 (with air)
08	Burner 2 operation
R8	Burner 2 operation (with air)
H8	Delay
P9	Post-purge

## Program step/status

---

DISPLAY <sup>1)</sup>	Program step/status
□□□□	Data transfer (programming mode)
--	Device Off

<sup>1)</sup> In Manual mode, four dots flash on the display.

<sup>2)</sup> Air actuator (control element/valve) is open.

## 9 Fault messages

Fault message (flashing)	DISPLAY	Description
Burner 1 flame simulation	E 01	Flame simulation/Flame signal before ignition
No flame after safety time 1	E 02	No flame formation to end of 1 <sup>st</sup> safety time
Flame failure during flame proving period 1 $t_{FS1}$	E 03	
Flame failure during burner 1 operation	E 04	Flame failure during operation
Burner 2 flame simulation	E 05	Flame simulation/Flame signal before ignition
No flame after safety time 2	E 06	No flame formation to end of 2 <sup>nd</sup> safety time
Flame failure during flame proving period 2 $t_{FS2}$	E 07	
Flame failure during burner 2 operation	E 08	Flame failure during operation
Too many remote resets	E 10	Remote reset activated > 5 × in 15 min.
Too many restarts for burner 1	E 11	> 5 restarts in 15 minutes
Too many restarts for burner 2	E 12	> 5 restarts in 15 minutes
Simultaneous activation (terminals 40 and 41)	E 21	“Maximum capacity” and “Ignition capacity” position feedback from butterfly valve set simultaneously
Actuator wiring (terminals 65–67)	E 22	Faulty wiring of terminals 65–67
Actuator feedback (terminals 40, 41)	E 23	Maximum or ignition capacity is not constantly signalled back to terminal 40 or 41
Simultaneous Min./Max. bus command	E 24	“Open actuator” and “Close actuator” bus signals set simultaneously
Non-fail-safe parameters (NFS) inconsistent	E 30	NFS parameter range is inconsistent
Fail-safe parameters (FS) inconsistent	E 31	FS parameter range is inconsistent
Mains voltage	E 32	Operating voltage too high/low
Faulty parameterization	E 33	Parameter set contains illegal settings
Air valve control defective	E 34	Faulty actuation of the air valve. Voltage is applied to the outputs at terminals 65–67 for the air valve.
Incompatible bus module	E 35	Bus module does not support the selected function.
Power module defective	E 36	Relay contact fault caused by defective relay contacts, EMC influence, by applying voltage to outputs or by an incorrect load module
Fuse defective	E 39	Device fuse F1 is defective
Inlet valve(s) leaking	E 40	Leak found on inlet valve
Outlet valve(s) leaking	E 41	Leak found on outlet valve
Pressure switch/gas valve wiring	E 44	
Gas valve wiring	E 45	Reversed valve connection
Safety interlock failure	S1	

## Fault messages

Fault message (flashing)	DISPLAY	Description
Permanent remote reset	E 52	Remote reset input activated > 10 s
Timing cycle too short	E 53	Minimum timing cycle not observed
Waiting for ignition position (LDS)	E 54	Faulty feedback signal of the control element position for ignition capacity
Incorrect voltage supply to terminal 6	E 57	Flameless mode without HT signal
Internal error	E 80	Flame amplifier error/Device error
Internal error	E 89	Error in processing internal data
Flame amplifier or fuses defective	E 91	Check the wiring and fuses
Irregularities in the power supply	E 92	Direct voltage is connected or signal inputs and L are connected to different phases
Internal error	E 94	Error at digital inputs
Internal error	E 95	Error at digital outputs
Internal error	E 96	Error when checking the SFR
No PCC, power module error	E 97	Insert compatible PCC, rectify power module contact error
Internal error	E 98	Error when writing to the EEPROM
emBoss	E 99	Shut-down without application error
Minimum capacity not reached	E Rc	Position for minimum capacity has not been reached after 255 s
Maximum capacity not reached	E Ro	Position for maximum capacity has not been reached after 255 s
Ignition capacity not reached	E Ri	Position for ignition capacity has not been reached after 255 s
Communication with bus module	Eb E	Bus module fault
Parameter chip card (PCC)	E Cc	Incorrect or defective PCC
POC valve open	Ec 1	No input signal for closed valve
POC valve closed	Ec 8	Valve not open
Air monitor "no flow" state	Ed 0	Fault Air monitor "no flow" state check. The signal from the pressure switches is received at terminal 36 or 37 before the air actuator is opened.
Low air pressure	Ed 1	Fault Air monitor operating check
Low air pressure (display E d2, E d3, E d4, E d5, E d6, E d7 or E d8)	Ed 2 to Ed 8	No input signal from pressure switch or failure in air supply during program step 2, 3, 4, 5, 6, 7 or 8
Air flow during pre-purge	Ed P	Air flow failure during pre-purge
Waiting for connection	n 0	BCU waiting for connection to controller
Invalid address	n 1	Invalid or incorrect address set on bus module
Invalid configuration	n 2	The bus module has received an incorrect configuration from the controller
Invalid network name	n 3	Invalid network name or no address allocated in the network name

## Fault messages

<b>Fault message (flashing)</b>	<b>DISPLAY</b>	<b>Description</b>
Controller in STOP position	n 4	Controller in STOP position
Burner 1 flame simulation	<b>E R1</b>	Burner 1 flame simulation while air actuator is open
No flame after safety time 1	<b>E R2</b>	No flame during safety time 1 while air actuator is open
Flame failure during flame proving period 1	<b>E R3</b>	Flame failure during flame proving period 1 while air actuator is open
Flame failure during burner 1 operation	<b>E R4</b>	Flame failure during burner 1 operation while air actuator is open
Burner 2 flame simulation	<b>E R5</b>	Burner 2 flame simulation while air actuator is open
No flame after safety time 2	<b>E R6</b>	No flame during safety time 2 while air actuator is open
Flame failure during flame proving period 2	<b>E R7</b>	Flame failure during flame proving period 2 while air actuator is open
Flame failure during burner 2 operation	<b>E R8</b>	Flame failure during burner 2 operation while air actuator is open

## 10 Parameter

Any changes to parameters will be saved to the parameter chip card.

### 10.1 Application parameters

Name	Parameter	Value range	Factory default settings
page 63 (Burner 1 flame signal FS1 switch-off threshold)	A001	2–20 = Burner 1 flame signal switch-off threshold in $\mu\text{A}$ (depending on I004)	2–20 $\mu\text{A}$ where I004 = 0, 3 or 4, 5–20 $\mu\text{A}$ where I004 = 1, 4 or 6, 5 $\mu\text{A}$ where I004 = 2, 7 or 8
page 63 (Burner 2 flame signal FS2 switch-off threshold)	A002	2–20 = Burner 2 flame signal switch-off threshold in $\mu\text{A}$ (depending on I004)	2–20 $\mu\text{A}$ where I004 = 0, 5 or 7, 5–20 $\mu\text{A}$ where I004 = 1, 3 or 8, 5 $\mu\text{A}$ where I004 = 2, 4 or 6
page 64 (Flame simulation check in standby position)	A003	0 = Off 1 = On	0
page 66 (High temperature operation)	A006	0 = Off 2 = Burner 1 with UVS and burner 2 with UVS 3 = Continuous operation with ionization/UVC 1 6 = Intermittent operation with UVS and burner 2 with ionization	0
page 69 (Burner 1 start-up attempts)	A007	1 = 1 start-up attempt 2 = 2 start-up attempts 3 = 3 start-up attempts	1
page 70 (Burner 2 start-up attempts)	A008	1 = 1 start-up attempt 2 = 2 start-up attempts 3 = 3 start-up attempts	1

## Parameter

Name	Parameter	Value range	Factory default settings
page 77 (Restart)	A009	0 = Off 1 = Burner 1 2 = Burner 2 3 = Burner 1 and burner 2 (pilot and main burners) 4 = Max. 5 × in 15 min. for burner 1 5 = Max. 5 × in 15 min. for burner 2 6 = Max. 5 × in 15 min. for burner 1 and burner 2	0
page 79 (Safety time during operation)	A019	0; 1; 2; 3; 4 = Time in seconds	1
page 80 (Over-run time tNL)	A039	0–60 = Time in seconds	0
page 80 (Running time selection)	A041	0 = Off; checking the positions for minimum/maximum capacity 1 = On; for approaching the positions for minimum/maximum capacity 2 = On; for approaching the position for maximum capacity 3 = On; for approaching the position for minimum capacity	0
page 80 (Running time)	A042	0–250 = Running time in seconds (can only be selected if I020 = 2 or 3)	250
page 81 (Over-run)	A043	0 = Off 1 = Post-ventilation 2 = Low fire; actuator feedback 3 = Low fire; time-bound	0
page 82 (Air actuator control)	A048	0 = Opens on external activation 1 = Opens with gas stage 1 2 = Opens with gas stage 2 4 = Opens with V4 burner 1	0
page 83 (Air actuator on start-up can be activated externally)	A049	0 = Cannot be activated 1 = Can be activated externally	0
page 84 (Air actuator in the event of fault)	A050	0 = Cannot be activated 1 = Can be activated externally	1
page 85 (Valve proving system)	A051	0 = Off 1 = Tightness test before start-up 2 = Tightness test after shut-down 3 = Tightness test before start-up and after shut-down	0
page 85 (Relief valve (VPS))	A052	2 = V2 3 = V3 4 = V4 5 = V5	2
page 86 (Measurement time for Vp1)	A056	3 = Time in seconds 5–25 = in 5 s steps 30–3600 = in 10 s steps	3600
page 86 (Valve opening time tL1)	A059	2–25 = Time in seconds	2

Name	Parameter	Value range	Factory default settings
page 89 (Proof of closure function test period)	A060	0–6000 = Time in seconds	10
page 78 (Minimum operating time tB)	A061	0–250 = Time in seconds	0
page 87 (Minimum pause time tMP)	A062	0–3600 = Time in seconds	0
page 88 (Operating time in Manual mode)	A067	0 = Unlimited 1 = 5 minutes	1
page 84 (Combustion mode)	A074	0 = Flame mode 2 = High temperature operation without ignition 3 = High temperature operation without burner 1 start	0
page 71 (Burner application)	A078	0 = Burner 1 1 = Burner 1 with pilot gas 2 = Burner 1 and burner 2 3 = Burner 1 and burner 2 with pilot gas 4 = Two-stage burner 1 5 = Burner 1 and two-stage burner 2	0
page 74 (Pilot burner)	A079	0 = With shut-down 1 = Controlled externally 2 = To start	0
page 90 (Fieldbus communication)	A080	0 = Off 1 = With address check 2 = No address check	0
page 90 (K-SafetyLink)	A081	0 = Off 1 = On	0
page 91 (Safety interlocks (bus))	A085	1 = Via fail-safe bus (K-SafetyLink) 2 = Via terminal 5 = Via fail-safe bus (K-SafetyLink) and terminal	2
page 91 (Purge (bus))	A087	0 = Off 1 = Via fail-safe bus (K-SafetyLink) 2 = Via terminal 3 = Via non-fail-safe bus 4 = Via fail-safe bus (K-SafetyLink) or terminal	2
page 91 (High temperature operation (bus))	A088	0 = Off 1 = Via fail-safe bus (K-SafetyLink) 2 = Via terminal 5 = Via fail-safe bus (K-SafetyLink) and terminal	2
page 91 (LDS (bus))	A089	0 = Off 1 = Via fail-safe bus (K-SafetyLink) 2 = Via terminal 5 = Via fail-safe bus (K-SafetyLink) and terminal	2

## Parameter

Name	Parameter	Value range	Factory default settings
page 75 (Safety time 1 tSA1)	A094	2–15 s = Time in seconds	
page 75 (Flame proving period 1 tFS1)	A095	0–25 s = Time in seconds	
page 76 (Safety time 2 tSA2)	A096	2–10 s = Time in seconds	
page 76 (Flame proving period 2 tFS2)	A097	0–25 s = Time in seconds	
page 89 (Function of sensor 1)	A101	0 = No function 48 = POC V1 49 = POC V2 50 = POC V3 51 = POC V4 52 = POC V5 53 = TC	0
page 89 (Function of sensor 2)	A102	See A101	0
page 89 (Function of sensor 3)	A103	See A101	0

## 10.2 Interface parameters

Name	Parameter	Value range	Factory default settings
page 92 (Flame control)	I004	0 = Ionization 1 = UVS sensor 2 = UVC sensor 3 = Ionization control for burner 1/UVS control for burner 2 4 = Ionization control for burner 1/UVC control for burner 2 5 = UVS control for burner 1/ionization control for burner 2 6 = UVS control for burner 1/UVC control for burner 2 7 = UVC control for burner 1/ionization control for burner 2 8 = UVC control for burner 1/UVS control for burner 2	0
page 93 (Air actuator)	I020	0 = Off 2 = With IC 40 5 = With air valve	0
page 96 (Function of terminal 64)	I040*	0 = Off 2 = V5 3 = Bus output 1	0
page 97 (Contact 80, 81/82 function)	I050*	0 = Off 1 = Ready signal 2 = Air signal 3 = Purge signal 4 = Cooling air valve 5 = Flue gas valve 6 = Fault signal 7 = Burner 1 operating signal	6
page 97 (Contact 90, 91/92 function)	I051*	0 = Off 1 = Ready signal 2 = Air signal 3 = Purge signal 4 = Cooling air valve 5 = Flue gas valve 6 = Fault signal 7 = Burner 1 operating signal 8 = Burner 2 operating signal	1

## Parameter

Name	Parameter	Value range	Factory default settings
page 97 (Function of contact 95/96)	I052*	0 = Off 1 = Ready signal 2 = Air signal 3 = Purge signal 4 = Cooling air valve 5 = Flue gas valve 6 = Fault signal 7 = Burner 1 operating signal 8 = Burner 2 operating signal	7
page 97 (Function of contact 95/97)	I053*	0 = Off 1 = Ready signal 2 = Air signal 3 = Purge signal 4 = Cooling air valve 5 = Flue gas valve 6 = Fault signal 7 = Burner 1 operating signal 8 = Burner 2 operating signal	8
page 97 (Contact 85/86, 87 function)	I054*	0 = Off 1 = Ready signal 2 = Air signal 3 = Purge signal 4 = Cooling air valve 5 = Flue gas valve 6 = Fault signal 7 = Burner 1 operating signal 8 = Burner 2 operating signal	2
page 98 (Function of input 1)	I061*	0 = Off 4 = Safety interlocks 5 = Air 6 = Cooling air 7 = Air actuator R1 8 = Air actuator R2 9 = Start 1 10 = Start 2 11 = Reset 12 = Purge 13 = LDS start-up conditions 14 = High temperature operation	9
page 98 (Function of input 2)	I062*	See I061	11
page 99 (Function of input 3)	I063*	See I061	12

## Parameter

Name	Parameter	Value range	Factory default settings
page 99 (Function of input 4)	I064*	See I061	5
page 99 (Function of input 5)	I065*	See I061	10
page 99 (Function of input 6)	I066*	See I061	14
page 99 (Function of input 7)	I067*	See I061	0
page 99 (Function of input 35)	I068*	See I061	4
page 99 (Function of input 36)	I069*	0 = Off 1 = Sensor 1 2 = Sensor 2 3 = Sensor 3 4 = Safety interlocks 5 = Air 6 = Cooling air 7 = Air actuator R1 8 = Air actuator R2 9 = Start 1 11 = Reset 12 = Purge 13 = LDS start-up conditions 14 = High temperature operation	0 (on BCU 460) 1 (on BCU 465)
page 99 (Function of input 37)	I070*	See I069	0 (on BCU 460) 2 (on BCU 465)
page 100 (Function of input 38)	I071*	See I069	0 (on BCU 460) 3 (on BCU 465)
page 100 (Function of input 39)	I072*	See I061	13
page 100 (Function of input 40)	I073*	See I061	7
page 100 (Function of input 41)	I074*	See I061	8

\* Interface parameters I040 to I099 are set at the factory and normally do not need to be adjusted.

### **10.3 Scanning the parameters**

During operation, the four-digit 7-segment display shows the program step/status.

In addition to the flame signal and the fault history, all the parameters of the BCU can be scanned in numerical order by repeatedly pressing the Reset/Information button (for 1 s).

The parameter display is ended 60 seconds after the last time the button is pressed or by switching off the BCU.

The BCU displays -- when the mains switch is off. The parameters cannot be scanned when the BCU is switched off or when a fault or warning is displayed.

### 10.3.1 Flame control

The BCU is fitted with two OR-linked flame amplifiers, each of which evaluates whether an adequate flame signal is supplied by the burner to the flame amplifier using a flame rod or UV sensor.

### 10.3.2 Burner 1 flame signal FS1 switch-off threshold

Parameter A001

The sensitivity at which the burner control unit still detects a flame at burner 1 can be set using parameter A001.

As soon as the measured flame signal falls below the set value (2 to 20  $\mu\text{A}$ ), the BCU performs a fault lock-out during start-up after the elapse of safety time 1 (parameter A094) or during operation after the elapse of the safety time during operation (parameter A019).

In the case of UV control, this value can be increased, should the burner to be monitored be influenced by other burners, for example.

The adjustable range for the flame signal switch-off threshold for burner 1 is dependent on the setting of interface parameter I004, see page 92 (Flame control):

I004 = 0, 3 or 4 (ionization control of burner 1): 2–20  $\mu\text{A}$ ,

I004 = 1, 5 or 6 (control of burner 1 using UVS sensor):

5–20  $\mu\text{A}$ ,

I004 = 2 (control of burner 1 using UVC sensor): 5  $\mu\text{A}$

### 10.3.3 Burner 2 flame signal FS2 switch-off threshold

Parameter A002

The sensitivity at which the burner control unit still detects a flame at burner 2 can be set using parameter A002.

As soon as the measured flame signal falls below the set value (2 to 20  $\mu\text{A}$ ), the BCU performs a fault lock-out during start-up after the elapse of safety time 2 (parameter A096)

or during operation after the elapse of the safety time during operation (parameter A019).

In the case of UV control, this value can be increased, should the burner to be monitored be influenced by other burners, for example.

The adjustable range for the flame signal switch-off threshold for burner 2 is dependent on the setting of interface parameter I004 (Flame control):

I004 = 0, 5 or 7 (ionization control of burner 2): 2–20  $\mu\text{A}$ ,

I004 = 1, 3 or 8 (control of burner 2 using UVS sensor):

5–20  $\mu\text{A}$ ,

I004 = 2, 4 or 6 (control of burner 2 using UVC sensor):

5  $\mu\text{A}$ \*

*\* The switch-off threshold is set at the UVC sensor.*

### 10.3.4 Flame simulation check in standby position

Parameter A003

This defines the instant for the flame simulation check.



Parameter A003 = 0: flame simulation check in standby position. The flame simulation check is conducted provided no start-up signal (start 1) is applied (during the so-called start-up position/standby). This allows fast start-up of the burner since there is no waiting time  $t_W$ .

The burner must have been switched off for at least 4 s before start-up in order for the flame simulation check to be conducted correctly.

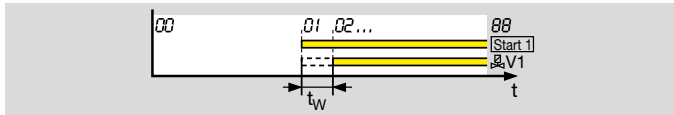

Parameter A003 = 1: flame simulation check on start-up. The flame simulation check is conducted after applying the start-up signal (start 1 or start 2) during the waiting time  $t_W$ .

#### What is flame simulation?

Flame simulation means that an extraneous signal is detected as a flame signal out of sequence. If the BCU detects such an extraneous signal during the flame simulation check, it starts the flame simulation delay time  $t_{LV1}$  (pilot burner) or  $t_{LV2}$  (main burner) for 25 s each. If the extraneous signal disappears during this time, the pilot or main burner can start. Otherwise, a fault lock-out occurs.

Flame simulation during  $t_{LV1}$ :

E 01 flashes on the display.

Flame simulation check in standby position (parameter A003 = 0):

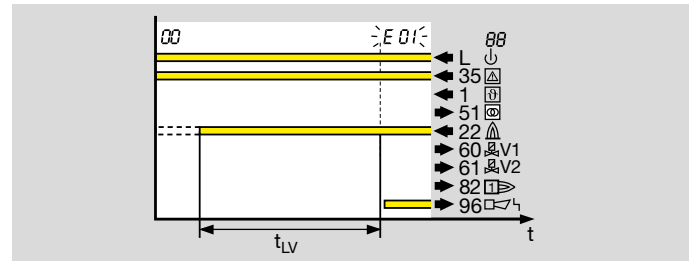

Flame simulation check on start-up (parameter A003 = 1):

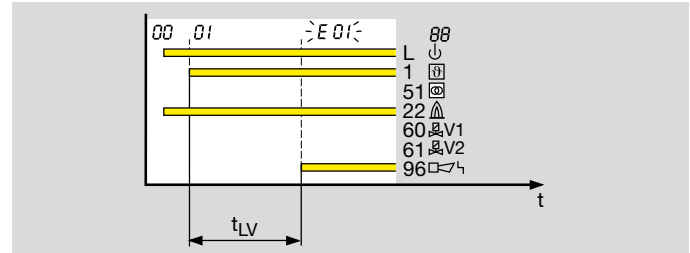

The flame simulation check of the pilot burner is always active until valve V3 is enabled.

## Parameter

Flame simulation during  $t_{LV2}$  (with permanent pilot burner only):

$E 05$  flashes on the display.

Flame simulation check in standby position (parameter  $A003 = 0$ ):

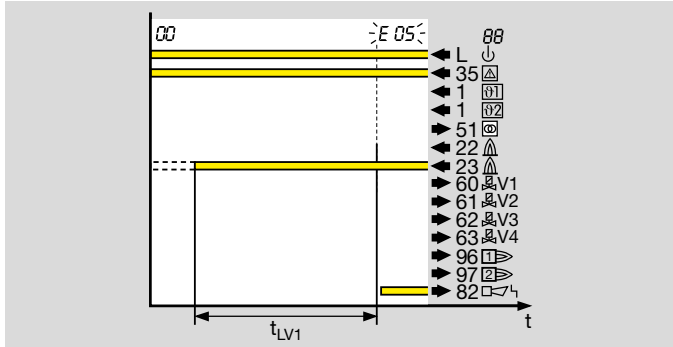

Flame simulation check on start-up (parameter  $A003 = 1$ ):

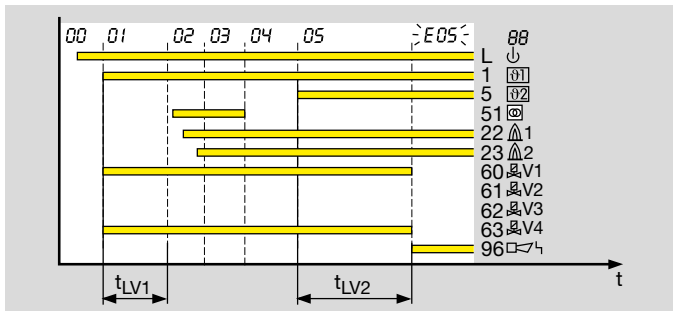

The flame simulation check of the main burner is always active until valve V2 is enabled.

### 10.3.5 High temperature operation

Parameter A006

Operation of firing systems above 750°C. The BCU..D1 and BCU..D2 have a fail-safe input with the function “High temperature operation”. If firing systems are operated above 750°C, the system is considered to be an item of high temperature equipment (see EN 746-2). Here, flame control must be in operation until the furnace wall temperature has exceeded 750°C.

Below 750°C, the flame is monitored by conventional means (UV sensor or flame rod). In High temperature mode (> 750°C), the flame may be controlled via the temperature using a safety temperature monitor (STM) in order to increase the system’s availability. This means that no incorrect flame signals, e.g. signals from a UV sensor which interprets reflected UV radiation as extraneous signals, may lead to faults.

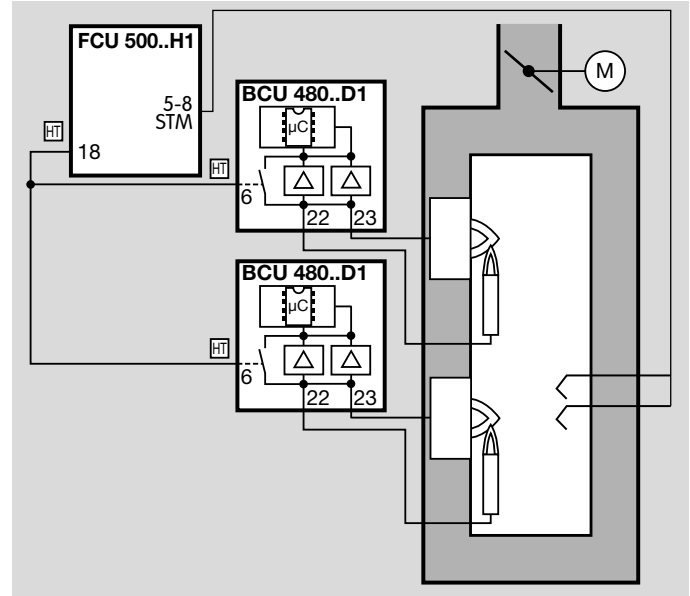

When the HT input is activated (terminal 6), the burner control unit reverts to High temperature mode, i.e.: **the BCU operates without evaluation of the flame signal. The safety function of the device’s internal flame control system is deactivated.**

In High temperature mode, the gas valves are opened and the burners are started as usual without monitoring the presence of a flame.

The precondition for this operating mode is that an external flame supervision device ensures the presence of the flame in a fail-safe manner indirectly via the temperature. For this purpose, we recommend a safety temperature monitor with double thermocouple (DIN 3440). The flame must be monitored again by conventional means (UV sensor or flame rod)

## Parameter

in the event of sensor discontinuity or short-circuit, failure of the safety temperature monitor or power failure.

The voltage may be applied to the HT input (terminal 6) so as to activate High temperature operation only when the temperature at the furnace wall has exceeded 750°C.

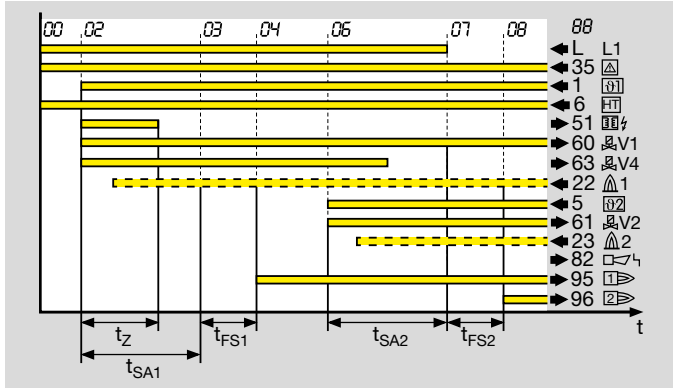

If the temperature in the furnace chamber drops below 750°C, the HT input must be disconnected from the electrical power supply and the furnace must then be operated with flame control.

The BCU then responds, depending on setting:

Parameter A006 = 0

The High temperature mode function is switched off. Flame control takes place dependent on the setting in parameter I004 using a flame rod, a UVS sensor or a UVC sensor.

Parameter A006 = 2 (BCU..D1)

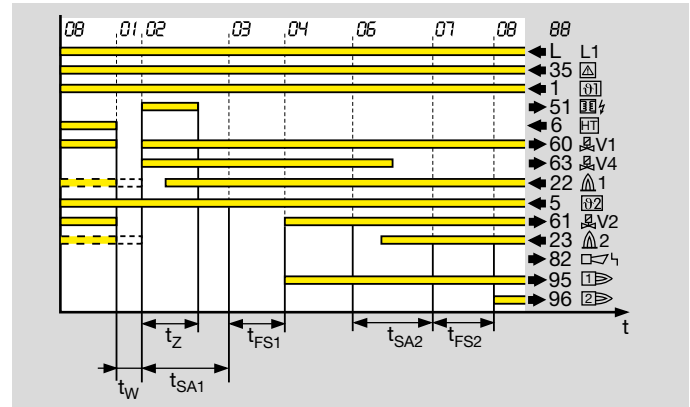

The BCU switches off burner 1 and burner 2 and restarts with flame simulation check (recommended in the case of UV control with UVS).

Parameter A006 = 3 (BCU..D1)

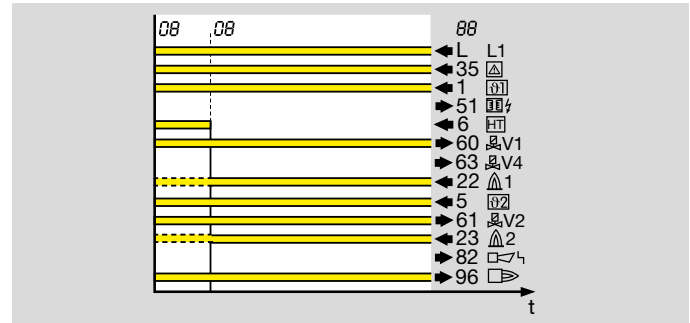

The burners remain in operation and the BCU performs flame control again on both burners (recommended for ionization control or UV control with UVC).

## Parameter

Parameter A006 = 6 (BCU..D2)

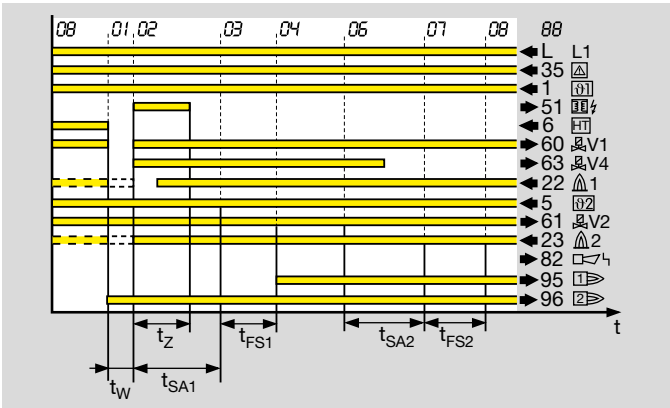

The BCU switches off burner 1 and restarts it with flame simulation check. Burner 2 continues to operate as long as no flame failure occurs.

If no flame signal is present when High temperature mode is deactivated, the burner control unit performs a fault lock-out, regardless of parameter A006.

Pilot burner fault

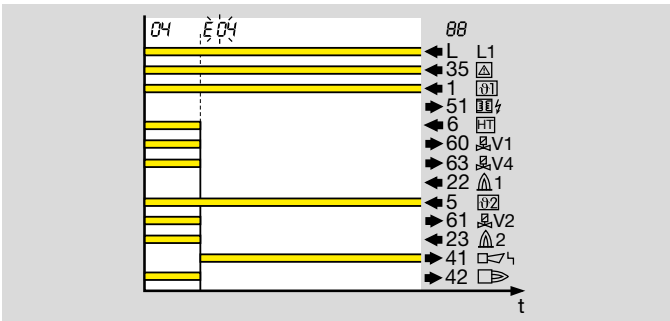

Main burner fault

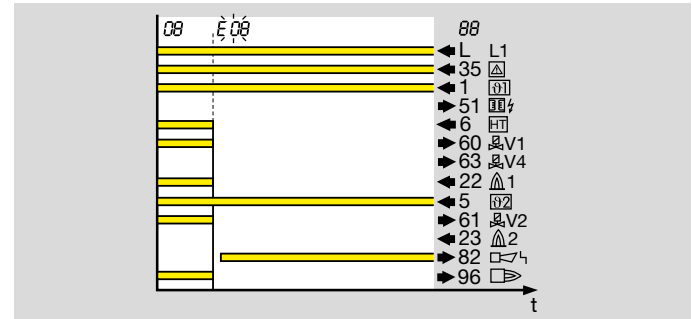

## 10.4 Behaviour during start-up

### 10.4.1 Burner 1 start-up attempts

This parameter defines the maximum number of possible start-up attempts of burner 1.

**Taking into account national standards and requirements, it must be clarified whether multiple start-up attempts are permitted.**

In accordance with EN 746-2, a restart may be conducted only if the safety of the installation is not impaired.

Multiple start-up attempts are not permitted under NFPA 86. If no flame forms during start-up, this must result in a fault lock-out..

If no flame is detected during start-up, an immediate fault lock-out (A007 = 1) or up to two additional start-up attempts (A007 = 2, 3) are performed depending on parameter A007.

Parameter A007 = 1: 1 start-up attempt.

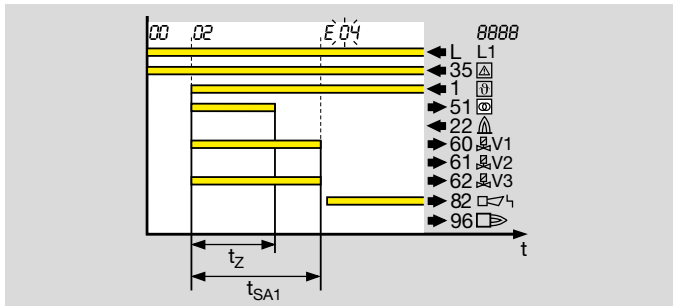

If no flame is formed during the start-up, so that at the end of the safety time  $t_{SA1}$  no flame signal is detected, this will result in a BCU safety shut-down with subsequent fault lock-out. The fault message **E 04** will flash in the BCU display depending on the burner operating mode.

Parameter A007 = 2, 3:  
2 or 3 start-up attempts.

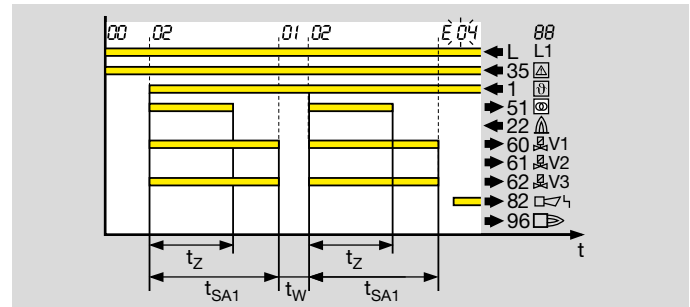

If no flame is formed during the start-up, so that at the end of the safety time  $t_{SA1}$  no flame signal is detected, the BCU closes the gas valves and repeats the start-up. Each start-up attempt begins with the parameterized start-up behaviour.

If the safety time  $t_{SA1}$  elapses without a flame signal having been detected, even after the last parameterized start-up attempt, this will result in a BCU safety shut-down with subsequent fault lock-out. The fault message **E 04** will flash in the BCU display depending on the burner operating mode.

### 10.4.2 Burner 2 start-up attempts

Parameter A008

This parameter defines the maximum number of possible start-up attempts of burner 2.

**Taking into account national standards and requirements, it must be clarified whether multiple start-up attempts are permitted.**

In accordance with EN 746-2, a restart may be conducted only if the safety of the installation is not impaired.

Multiple start-up attempts are not permitted under NFPA 86. If no flame forms during start-up, this must result in a fault lock-out..

If no flame is detected during start-up, an immediate fault lock-out (A008 = 1) or up to two additional start-up attempts (A008 = 2, 3) are performed depending on parameter A008.

Parameter A008 = 1: 1 start-up attempt.

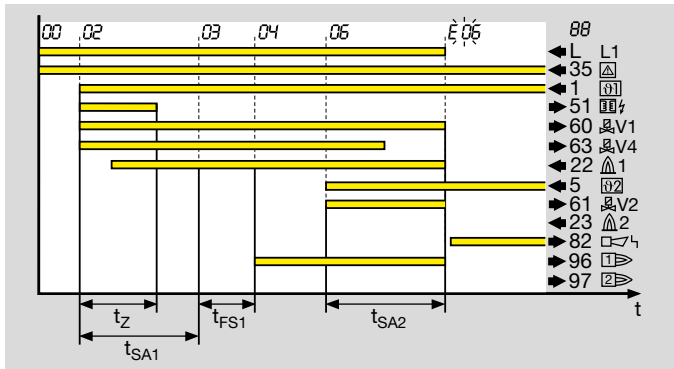

If no flame is formed during the start-up, so that at the end of the safety time  $t_{SA2}$  no flame signal is detected, this will result in a BCU safety shut-down with subsequent fault

lock-out. The fault message  $E 04$  will flash in the BCU display depending on the burner operating mode.

Parameter A008 = 2, 3: 2 or 3 start-up attempts.

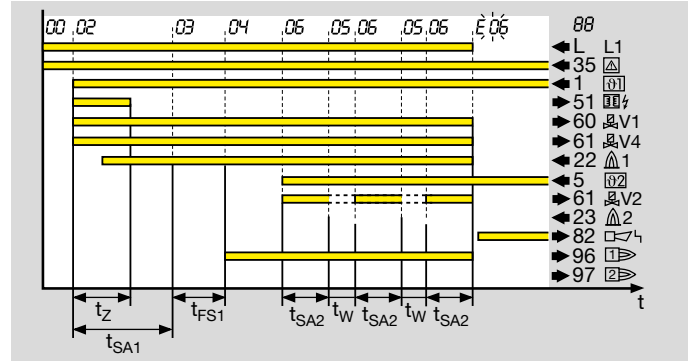

If no flame is formed during the start-up, so that at the end of the safety time  $t_{SA2}$  no flame signal is detected, the BCU closes the gas valves and repeats the start-up. Each start-up attempt begins with the parameterized start-up behaviour.

If the safety time  $t_{SA2}$  elapses without a flame signal having been detected, even after the last parameterized start-up attempt, this will result in a BCU safety shut-down with subsequent fault lock-out. The fault message  $E 08$  will flash in the BCU display depending on the burner operating mode.

### 10.4.3 Burner application

Parameter A078

This parameter enables the BCU to be adjusted to various burner applications. In addition, an optional pilot gas valve (V3) can be parameterized via which the burner is started with a defined ignition capacity.

Parameter A078 = 0: burner 1. Two valves (V1, V2) are included for the burner. These are connected to the valve outputs (terminals 60 and 61). Valves V1 and V2 are opened in parallel to start the burner in order to release the gas supply to the burner.

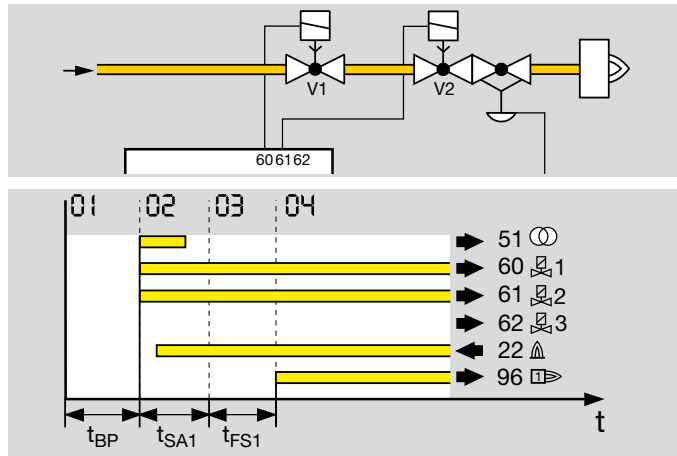

Parameter A078 = 1: burner 1 with pilot gas. Three valves (V1, V2 and V3) are included for a burner with a pilot gas valve. These are connected to the valve outputs (terminals 60, 61 and 62). Valves V1 and V3 open to start the burner. The burner is started with a limited ignition capacity using gas valve V3. After the elapse of the safety time  $t_{SA1}$  (pro-

gram step 02), valve V2 opens. Valve V3 limits the ignition capacity. After the elapse of the flame proving period  $t_{FS1}$  (program step 04), it is closed again.

For this application, it must be ensured that the flame proving period (parameter A095) is set to a value  $\geq 2$  s.

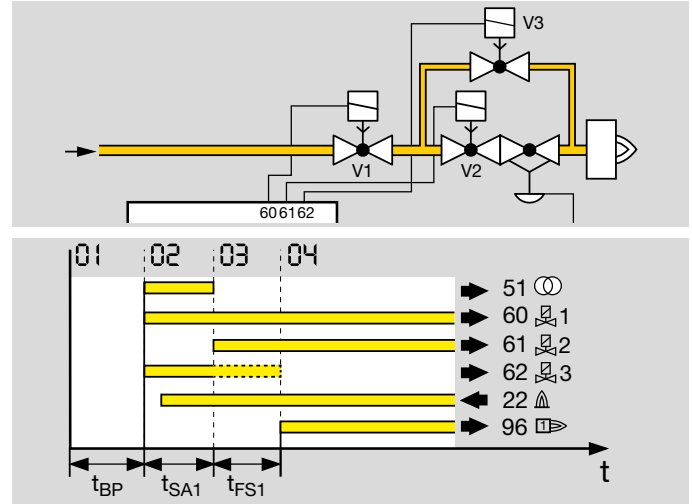

## Parameter

Parameter A078 = 2: burner 1 and burner 2. Three valves (V1, V2 and V4) are included for a modulating burner with a pilot burner. These are connected to the valve outputs (terminals 60, 61 and 63). Valves V1 and V4 open to start the pilot burner. Gas valve V2 releases the gas supply to the main burner. Gas valve V2 releases the gas supply to the main burner.

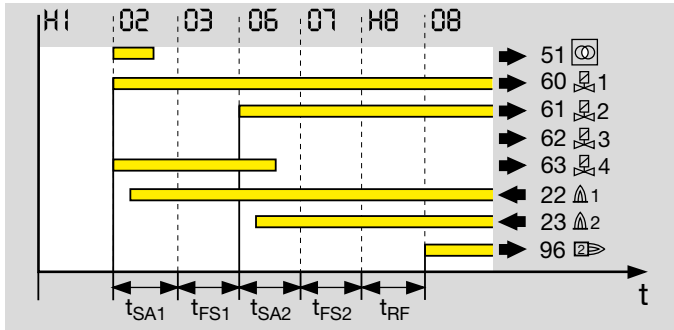
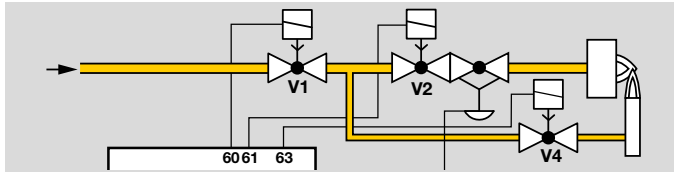

Parameter 78 = 3: burner 1 and burner 2 with pilot gas. In this application, the burner has an additional pilot gas valve V3. The valves are connected to the valve outputs (terminals 60, 61, 62 and 63). Valves V1 and V4 open to start the pilot burner. The burner is started with a limited ignition capacity using gas valve V3. After the elapse of the safety time  $t_{SA2}$  (program step 06), valve V2 opens (terminal 61). Pilot gas valve V3 is closed again after the elapse of the flame proving period  $t_{FS2}$  (program step 07).

For this application, it must be ensured that the flame proving period (A097) is set to a value  $\geq 2$  s.

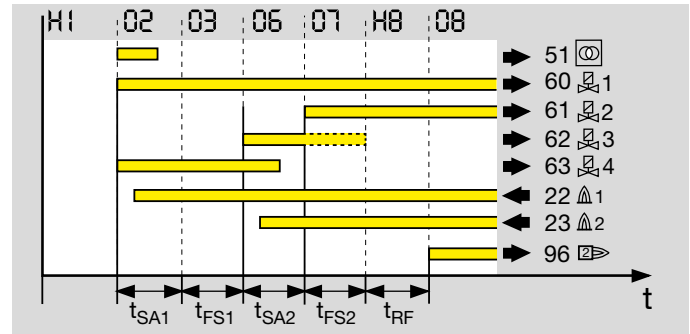
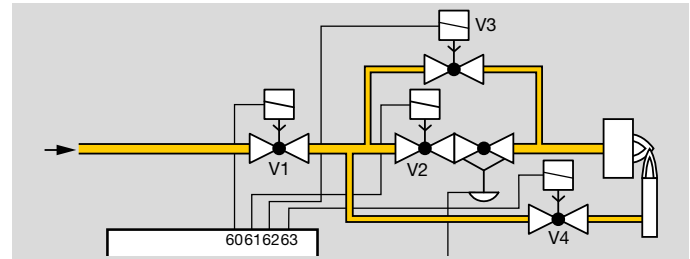

## Parameter

Parameter A078 = 4: two-stage burner 1. Three valves (V1, V2 and V3) are included for a two-stage burner. These are connected to the valve outputs (terminals 60, 61 and 62).

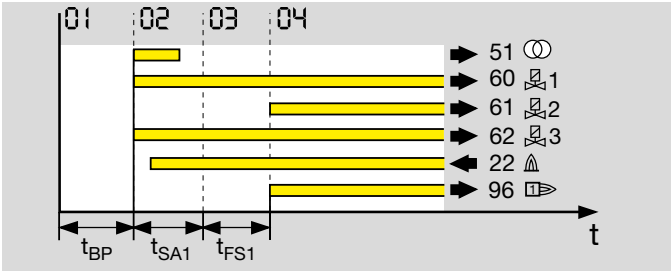
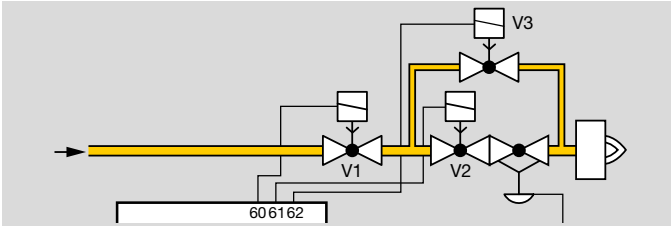

Valves V1 and V3 open to start the burner. The burner is started with a limited ignition capacity using gas valve V3. After the flame proving period  $t_{FS1}$  has elapsed, valve V2 opens to enable the 2<sup>nd</sup> gas stage.

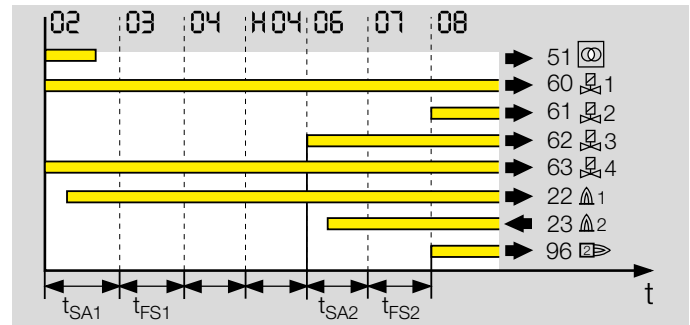
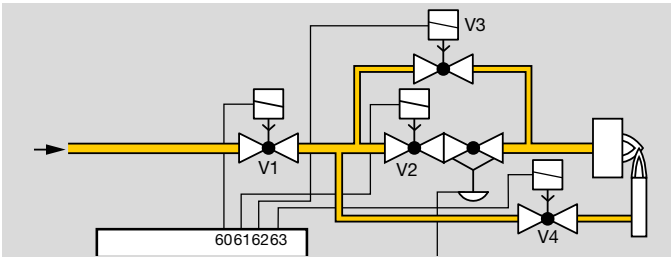

Parameter 78 = 5: burner 1 and two-stage burner 2. In this application, the burner has an additional pilot gas valve V3. The valves are connected to the valve outputs (terminals 60, 61, 62 and 63). Valves V1 and V4 open to start the pilot burner. The burner is started with a limited ignition capacity using gas valve V3. Valve V2 (terminal 61) can be opened with the operating signal (program step 08) in order to operate burner 2 at maximum capacity.

### 10.4.4 Pilot burner

Parameter A079

Burner 1 (pilot burner) is used to ignite burner 2 (main burner). The start-up/operating properties of burner 1 can be set using parameter A079.

Parameter A079 = 0: with shut-down.

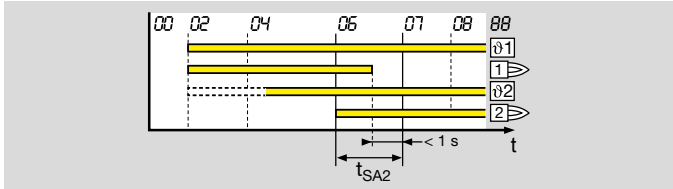

Burner 2 is started if burner 1 is in operation and start-up signal 2 is active. As soon as safety time  $t_{SA2}$  has just one second left to run, burner 1 is switched off regardless of start-up signal 1.

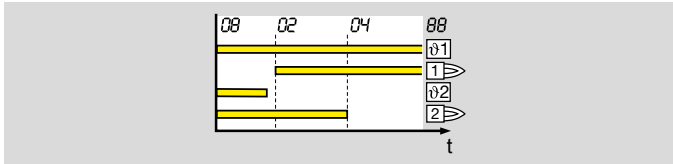

If start-up signal 2 is deactivated while burner 2 is in operation and start-up signal 1 is active, burner 1 is restarted. Burner 2 is deactivated as soon as burner 1 is in operation.

Parameter A079 = 1: controlled externally.

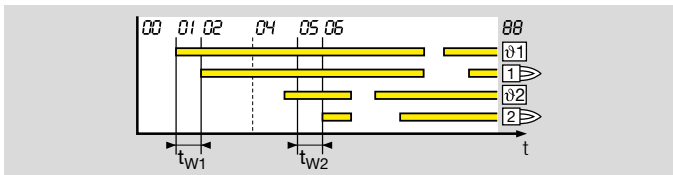

Burner 1 is started and deactivated depending on start-up signal 1. Burner 1 continues to operate even if the main burner is active.

Burner 2 can only be started if burner 1 is in operation. Parameter A079 = 2: to start.

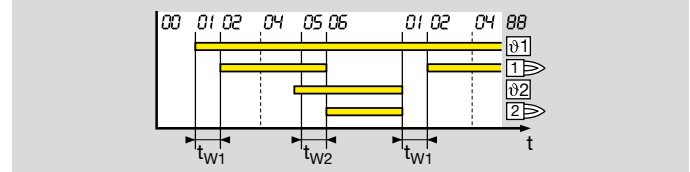

Burner 1 is started with start-up signal 1. Afterwards, burner 2 is started. As soon as safety time  $t_{SA2}$  has just one second left to run, burner 1 is deactivated regardless of the start-up signal. The start-up signal has no effect on the burner start.

Burner 2 is deactivated if start-up signal 2 is deactivated during operation. Burner 1 can be restarted after it has been shut down and after a successful flame simulation check by activating start-up signal 1.



### 10.4.7 Safety time 2 $t_{SA2}$

Parameter A096

During safety time 2  $t_{SA2}$ , the flame on burner 2 (main flame) is ignited. It can be set to between 2 and 10 s.

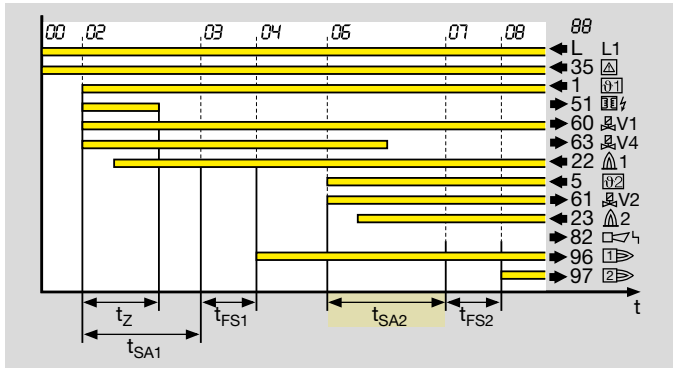

Safety time 2 starts with the application of the  $\text{B2}$  start-up signal (terminal 5). Valve V2 opens at the start of safety time 2. The fuel supply to burner 2 is released so that a flame can form. If no flame is detected at the end of safety time 2, the valves are closed again. Depending on parameter A008 (Burner 2 start-up attempts), the BCU reacts either with an immediate safety shut-down with fault lock-out (A008 = 1) or with one or two additional start-up attempts (A008 = 2 or 3). The BCU will complete a maximum of three start-up attempts.

**Safety time 2 must be determined on the basis of current national standards and regulations. The burner application and the burner capacity are the main criteria for this.**

If the  $\text{B1}$  start-up signal (terminal 1) drops out during safety time 2, valve V4 will not be switched off until the end of safety time 2.

### 10.4.8 Flame proving period 2 $t_{FS2}$

Parameter A097

Flame proving period 2  $t_{FS2}$  can be parameterized to enable the flame on burner 2 to stabilize after the elapse of safety time 2. Only when the flame proving period has elapsed will the next program steps be initiated by the BCU. The flame proving period can be set to between 0 and 25 s.

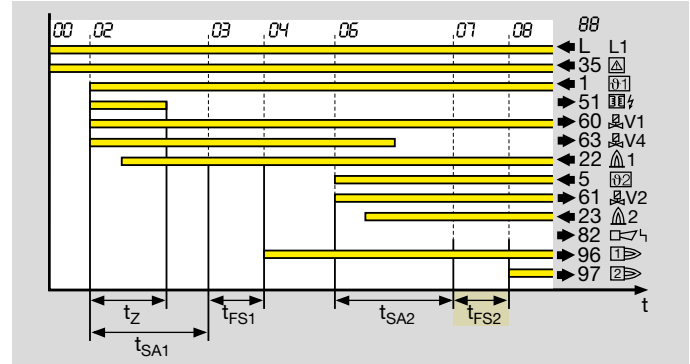

## 10.5 Behaviour during operation

### 10.5.1 Restart

Parameter A009

Restart can be programmed for burners which occasionally display unstable behaviour during operation.

This parameter determines whether the BCU initiates an immediate fault lock-out or an automatic restart after a safety shut-down during operation. Excessive restarts, however, can be detected.

**Taking into account national standards and requirements, it must be clarified whether the restart function may be used.**

In accordance with EN 746-2, a restart may be conducted only if the safety of the installation is not impaired.

The precondition for an automatic restart is that the burner can restart (as intended in all operating phases). In this case, it must be ensured that the program sequence started by the BCU matches the application.

Parameter A009 = 0: Off.

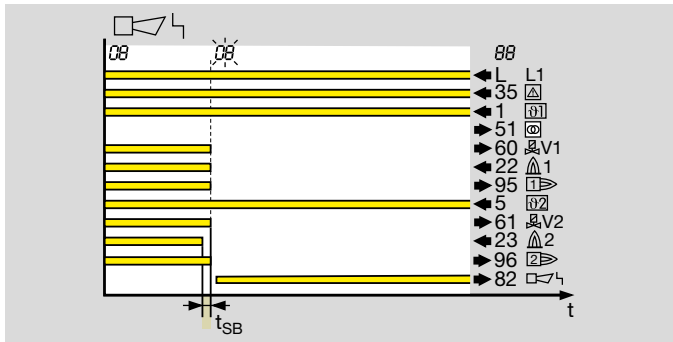

A safety shut-down with subsequent fault lock-out takes place in the event of flame failure during operation.

Parameter A009 = 1: burner 1. The restart function is active.

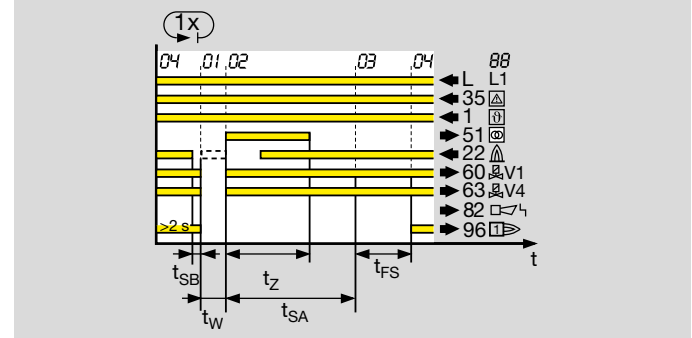

If a safety shut-down occurs during operation (minimum operating time of 2 s), the valves are closed and the operation signalling contact is opened within the safety time during operation  $t_{SB}$ . The burner control unit then attempts to restart the burner once. If the burner does not function, a safety shut-down with fault lock-out occurs. The display blinks and shows the fault message.

Parameter A009 = 2: burner 2.

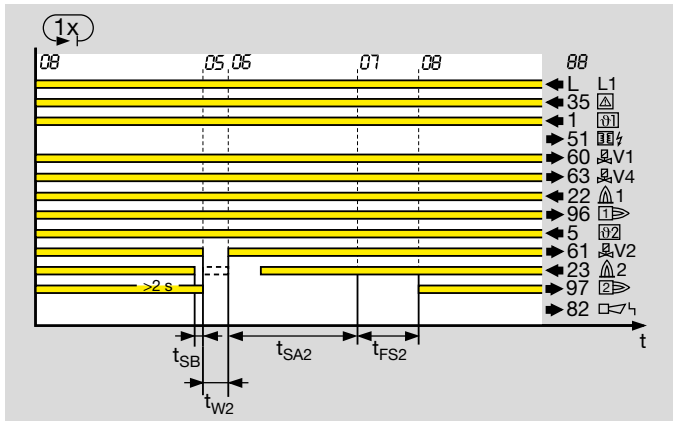

If a safety shut-down occurs during operation (minimum operating time of 2 s), valve V2 is closed and the operation signalling contact opened within the safety time during operation  $t_{SB}$ . The burner control unit then attempts to restart burner 2 once. If burner 2 does not function, a safety shut-down with fault lock-out occurs. The display blinks and shows the fault message.

Parameter A009 = 3: burner 1 and burner 2.

Parameter A009 = 4: max. 5 x in 15 min. for burner 1. The restart function is active and is also monitored for excessive restarts.

In certain conditions, it is possible that the restart function is repeated continuously without a safety shut-down with subsequent fault lock-out being performed. The BCU has a safety shut-down with subsequent fault lock-out option if more than 5 restarts are performed within a period of 15 minutes.

**Taking into account national standards and requirements, it must be clarified whether the option may be used.**

Parameter A009 = 5: max. 5 x in 15 min. for burner 2.

Parameter A009 = 6: max. 5 x in 15 min. for burner 1 and burner 2.

## 10.5.2 Minimum operating time $t_B$

Parameter A061

A minimum operating time (0 to 250 s) may be defined to ensure that the heating equipment operates stably.

If the minimum operating time is active, burner operation will be maintained until the set time has elapsed even if the start-up signal fails.

The minimum operating time starts as soon as the program step for operation/controller enable (display 08) has been reached.

If the start-up signal drops out before the start of operation/controller enable, e.g. during pre-purge, the burner control unit reverts directly to the start-up position (standby) and the burner is not ignited.

The minimum operating time can be cancelled by switching off the BCU or if a safety shut-down occurs.

## 10.6 Safety limits

Parameter A019 can be used to adjust the safety limits (safety time during operation) to the system requirements.

### 10.6.1 Safety time during operation

Parameter A019

Parameter A019 = 0; 1; 2; 3; 4: time in seconds

The safety time during operation is the time that the BCU needs to stop the fuel supply after a flame failure during operation or an interruption at the safety current inputs (terminals 36, 37 and 38). The safety time can be set to between 0 and 4 s in steps of 1 s. Prolonging the safety time during operation increases the installation availability in the case of brief-duration signal fades (e.g. fades of the flame signal).

The requirements of national standards and regulations must be satisfied.

In accordance with EN 298, the maximum reaction time to a flame failure must not exceed 1 s. Specific application standards may permit other values.

Under EN 746-2, the safety time of the installation during operation (total closing time) must not exceed 3 s.

Under NFPA 86, section 8.10.3\*, the maximum flame failure response time shall be  $\leq 4$  s.

## 10.7 Air control

### 10.7.1 Over-run time $t_{NL}$

Parameter A039

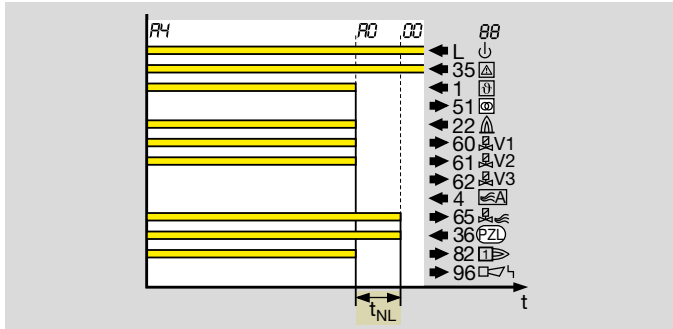

The air valve remains open for the programmed time (0 to 60 s) after the start-up signal ( 9) has been deactivated following a controlled shut-down. The burner control unit closes the actuator (air valve, actuator) after the elapse of the over-run time  $t_{NL}$ .

### 10.7.2 Running time selection

Parameter A041

Parameter A041 = 0: Off; checking the positions for minimum/maximum capacity. A signal that the positions for minimum and maximum capacity have been reached is returned and monitored with a timeout time of max. 250 s. When the position has been reached, the BCU will initiate the next program step.

Parameter A041 = 1: On; for approaching the positions for minimum/maximum capacity. The running time set using parameter A042 is activated for approaching these positions, see page 80 (Running time). After this time has elapsed, the BCU will initiate the next program step.

Parameter A041 = 2: On; for approaching the position for maximum capacity. The running time set using parameter A042 is activated for approaching the position for maximum capacity, see page 80 (Running time). After this time has elapsed, the BCU will initiate the next program step. Approaching the position for minimum capacity is signalled and monitored.

Parameter A041 = 3: On; for approaching the position for minimum capacity. No signal is returned that the position for minimum capacity has been reached. The running time set using parameter A042 is activated for approaching the position for minimum capacity, see page 80 (Running time). After this time has elapsed, the BCU will initiate the next program step. Approaching the position for maximum capacity is signalled and monitored.

### 10.7.3 Running time

Parameter A042

This parameter can be used to adjust the behaviour in the case of slow opening and closing air valves. The running time starts when the air actuator is switched off. A restart of the burner after a controlled shut-down, a start-up attempt, restart, cooling or purging is delayed until the end of the running time. After the running time has elapsed, the burner is started if the start-up signal ( 9) is applied.

The time should be adjusted such that the system can be set to ignition position, i.e. that the air actuator is closed before a start-up is initiated.

### 10.7.4 Over-run

Parameter A043

The over-run ( $t_{KN}$ ) supports applications with a pneumatic air/gas ratio control system and On/Off control. Using the over-run function reduces the  $O_2$  content in the furnace atmosphere.

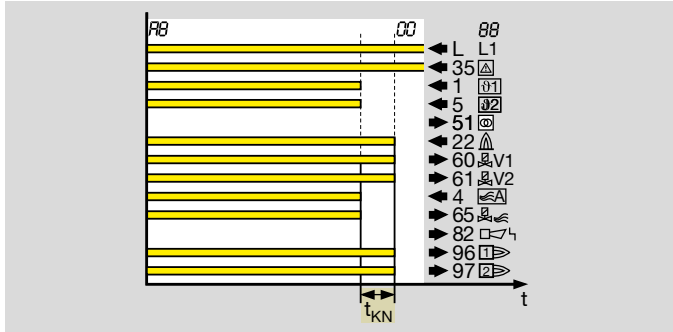

Parameter A043 = 0: Off. No over-run is performed. The gas circuit is closed immediately owing to a quick closing gas valve in the case of On/Off control. The air circuit is closed more slowly. The air flowing in during this time increases the  $O_2$  content in the combustion chamber.

Parameter A043 = 1: post-ventilation (with BCU/LM..F1 only). The gas supply will be closed. Air continues to be supplied for the programmed duration depending on parameter A039.

Parameter A043 = 2: low fire over-run until actuator feedback. The air actuator is closed with a deactivated start-up signal in the event of a controlled shut-down. The gas valves remain open for the programmed duration depending on parameter A039 (Over-run time) or until the air actuator is closed. The gas valves are closed immediately in the

event of a flame failure. A flame failure during the over-run does not result in a fault lock-out.

Parameter A043 = 3: low fire over-run, time-bound.

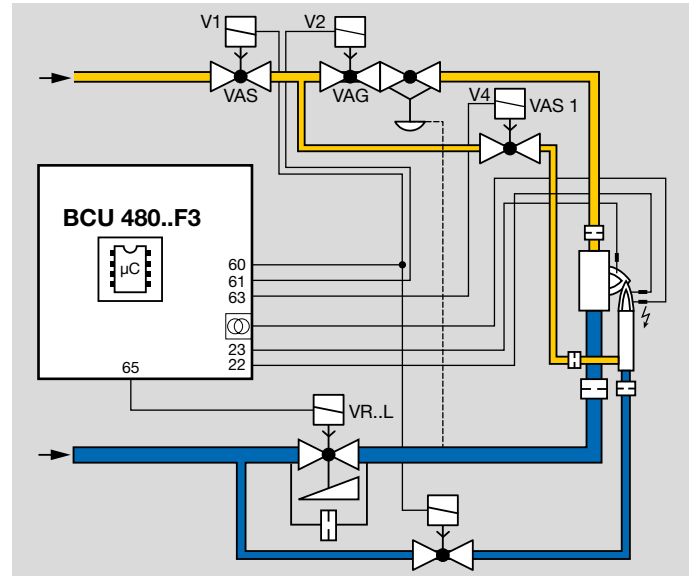

The burners are initially powered down to low-fire rate and remain in operation for the programmed duration depending on parameter A039 (Over-run time). Flame control is still operational. It must be ensured that no excess gas occurs.

### 10.7.5 Air actuator control

#### Parameter A048

In cyclic operation, parameters A048 and A049 on BCU..F1 and F3 determine the behaviour of the air actuator during burner start and burner operation.

The air actuator can be activated externally via the input at terminal 4 for cooling the burner in the start-up position (standby). This function is not available during burner start-up and during operation.

Parameter A048 = 0: opens on external activation.

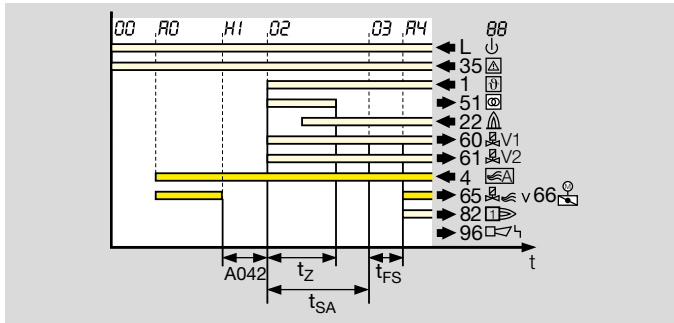

This setting together with parameter A049 = 0, see page 83 (Air actuator on start-up can be activated externally), is required for burners on which the air/gas ratio is controlled by a pneumatic air/gas ratio control system and which need to be started at low-fire rate, e.g. on two-stage-controlled burners, see page 9 (Two-stage-controlled main burner with permanent pilot burner). In this case, activation of the air actuator during burner start via the input at terminal 4 must be prevented.

External control allows switchover between low fire and high fire during operation.

Parameter A048 = 1: opens with gas stage 1 (start fuel flow rate).

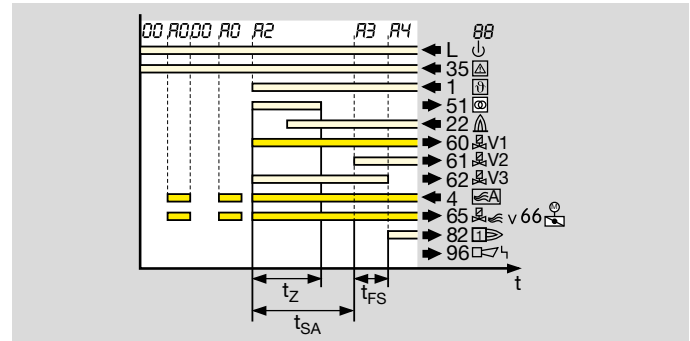

The air actuator opens at the same time as safety time  $t_{SA2}$  begins and the main burner starts.

Parameter A048 = 2: opens with gas stage 2 (operating fuel flow rate).

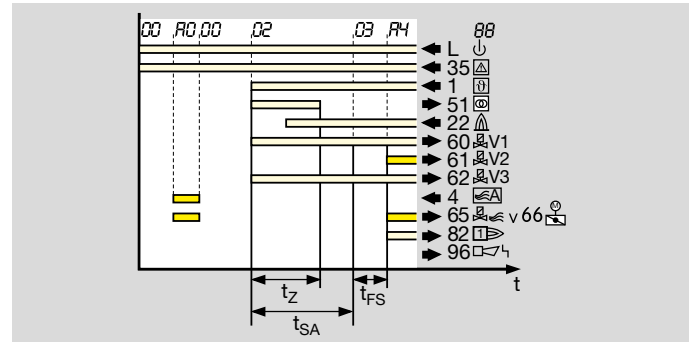

**This setting is required in the case of two-stage main burners which are switched ON/OFF via the 92 input.**

The air valve opens simultaneously with the operating signal for the main burner. The air valve can be activated externally via the input at terminal 4 for cooling the burner in the start-

## Parameter

up position/standby. This function is not available during burner start-up and during operation.

Parameter 48 = 1: opens with V4 burner 1.

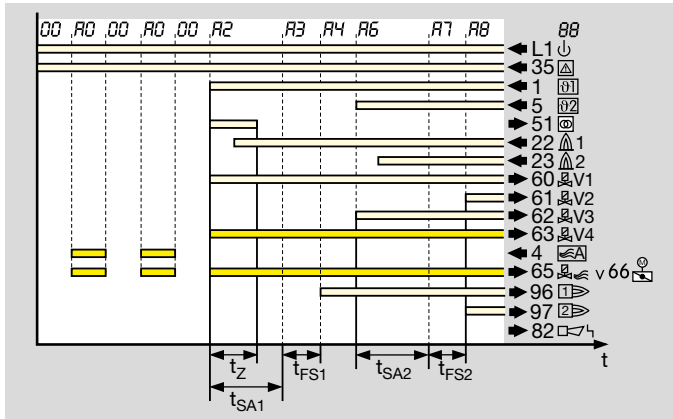

The air valve opens with the start fuel flow rate. The air valve can be activated externally via the input at terminal 4 for cooling the burner in the start-up position/standby.

### 10.7.6 Air actuator on start-up can be activated externally

Parameter A049

Parameter A049 = 0: cannot be activated.

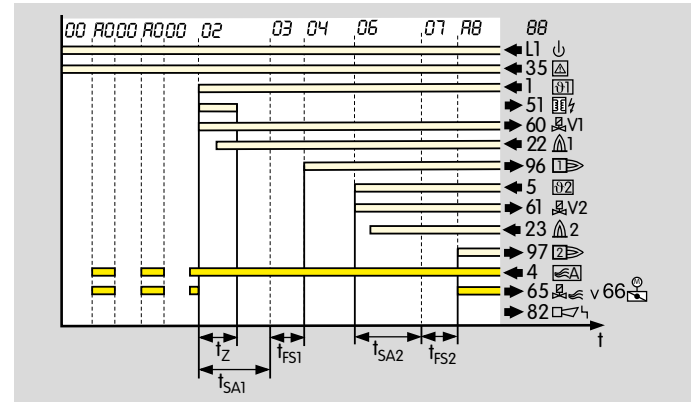

During start-up, the air actuator remains closed. The air actuator cannot be activated externally.

Parameter A049 = 1: can be activated externally.

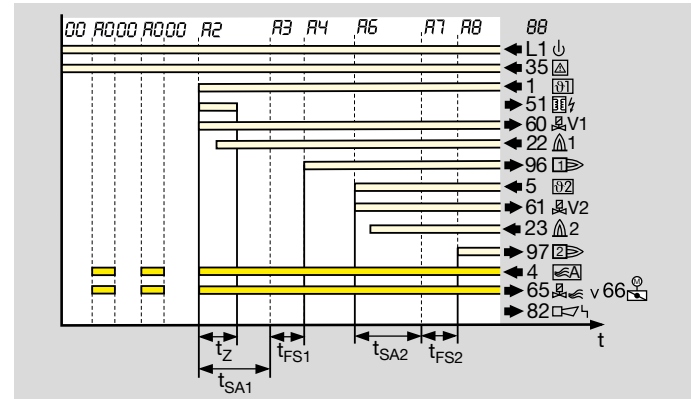

The air actuator can be activated externally via the input at terminal 4 during start-up. Parameter A048 must be set to 0 for this purpose, see also page 82 (Air actuator control).

### 10.7.7 Air actuator in the event of fault

Parameter A050

This parameter decides whether the air actuator can be activated externally via the input at terminal 4 in the event of a fault lock-out.

Parameter A050 = 0: cannot be activated. The air actuator remains closed in the event of a fault lock-out. It cannot be activated externally via terminal 4.

Parameter A050 = 1: can be activated externally. The air actuator can be activated externally via the input at terminal 4 during a fault, e.g. for cooling.

### 10.7.8 Combustion mode

Parameter A074

The type of combustion in which the ignition takes place can be set using parameter A074.

Parameter A074 = 0: Flame mode.

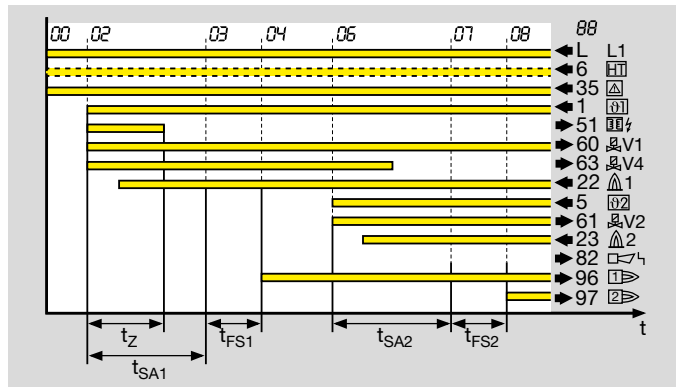

The burner is always started with ignition in Flame mode and in High temperature mode. Flame control is provided in

High temperature mode by the high temperature monitoring system.

Parameter A074 = 3: high temperature operation without burner 1 start.

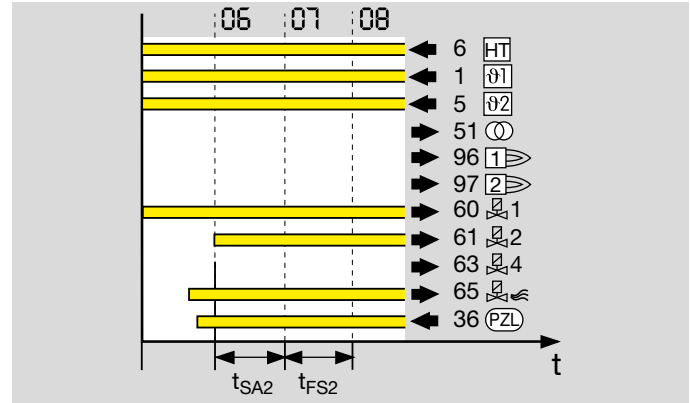

When connected to pilot and main burners, the BCU 480 can be parameterized so that the main burner is started automatically in HT mode. The pilot burner's start-up process is skipped. The start-up signals for burner 1 and burner 2 must be active.

## 10.8 Valve check

### 10.8.1 Valve proving system

Parameter A051

Parameter A051 is used to define whether and at what time in the BCU program sequence the valve check is activated. The tightness of the gas solenoid valves and the pipework between the valves are checked (tightness test). Parameter A051 = 0: Off. No valve check is activated.

Parameter A051 = 0: Off. No valve check is activated.

Parameter A051 = 1: tightness test before start-up.

Parameter A051 = 2: tightness test after shut-down. With this setting, a tightness test is also performed after a fault is reset and after mains on.

Parameter A051 = 3: tightness test before start-up and after shut-down.

An additional bypass valve must be installed in gas sections with an air/gas ratio control. This valve allows the closed air/gas ratio control to be bypassed during the tightness test.

### 10.8.2 Relief valve (VPS)

Parameter A052

One of the valves connected to terminal 61, 62, 63 or 64 can be selected to discharge the test volume during a tightness test.

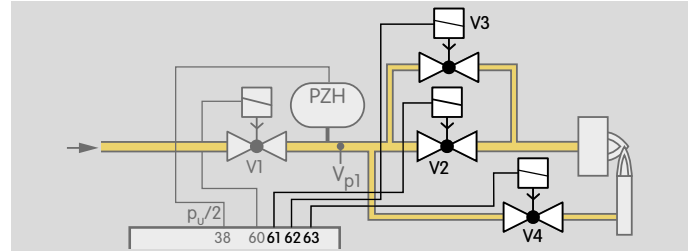

Parameter A052 = 2: V2. The valve on terminal 61 acts as the relief valve.

Parameter A052 = 3: V3. The valve on terminal 62 acts as the relief valve.

Parameter A052 = 4: V4. The valve on terminal 63 acts as the relief valve.

Parameter A052 = 5: V5. The valve on terminal 64 acts as the relief valve.

### 10.8.3 Measurement time for $V_{p1}$

Parameter A056

The required measurement time must be determined according to the requirements of the appropriate application standards, e.g. EN 1643.

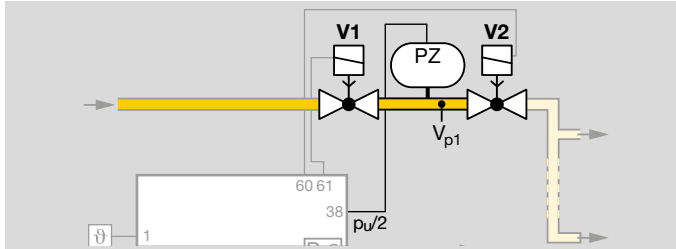

The required measurement time for the tightness test of  $V_{p1}$  can be set using parameter A056. It is adjustable from 3 to 3600 s.

See also page 35 (Measurement time  $t_M$ ).

### 10.8.4 Valve opening time $t_{L1}$

Parameter A059

This parameter is used to define the opening time for the valves (2 to 25 s) which are opened to fill or discharge the test volume between the gas valves. If the preset opening time  $t_L = 3$  s is inadequate (e.g. if slow opening valves are used) to fill the test volume or reduce the pressure between the valves, bypass valves can be used instead of the main valves.

On condition that the gas volume which flows into the combustion chamber is no larger than 0.083% of the maximum flow rate, the opening time of the bypass valves may be longer than the 3 s permitted by the standard (EN 1643:2000).

## 10.9 Behaviour during start-up

### 10.9.1 Minimum pause time $t_{MP}$

Parameter A062

A minimum pause time  $t_{MP}$  (0 to 3600 s) can be defined to achieve stable operation of the burners. If the over-run time set using parameter A039 has elapsed and no start-up signal is received at terminal 1 and terminal 5 (burner shut down), a restart and cooling are prevented for the duration of the minimum pause time  $t_{MP}$ .

If a signal is applied to terminal 1 (burner start-up) or terminal 2 (cooling) during the minimum pause time, status display Delay **H3** will appear.

## 10.10 Manual mode

If the Reset/Information button is pressed for 2 s during switch-on, the BCU reverts to Manual mode. Two dots flash on the display. The BCU is now operating in Manual mode independently of the status of the inputs for start-up signal (terminals 1 and 5), controlled air flow (terminal 4) and remote reset (terminal 2). The functions of the safety-relevant inputs such as controller enable/emergency stop (terminal 35) are retained. The manual start-up of the BCU can be initiated in Manual mode by pressing the Reset/Information button. Each time the button is pressed again, the BCU moves to the next step of the program sequence and stops there, for example for adjusting an actuator or the gas/air mixture.

### 10.10.1 Operating time in Manual mode

Parameter A067

Parameter A067 determines when Manual mode is terminated.

Parameter A067 = 0: Manual mode is not limited in time.

If this function has been selected, operation of the burner may be continued manually in the event of failure of the control system or the bus activation.

Parameter A067 = 1: the BCU will terminate Manual mode 5 minutes after the last time the button is pressed. It then moves abruptly back to the start-up position (standby).

If the unit is switched off or a power failure occurs, Manual mode on the BCU will be terminated regardless of parameter A067.

## 10.11 Sensors

A sensor (pressure switch or POC switch) can be connected to each of the inputs at terminals 36, 37 or 38, see also page 99 (Function of input 36).

Parameter A101, A102 or A103 is used to define the sensor function (the sensor type and the program status at which the sensor signal is evaluated by the BCU). Multiple sensors may be used in parallel for the same function if two or three inputs are assigned the same sensor function.

### 10.11.1 Function of sensor 1

Parameter A101

This parameter assigns a sensor function to terminal 36.

Parameter A101 = 48: proof of closure function V1. The closed position of valve V1 is monitored by the POC.

Parameter A101 = 49: proof of closure function V2. The closed position of valve V2 is monitored by the POC.

Parameter A101 = 50: proof of closure function V3. The closed position of valve V3 is monitored by the POC.

Parameter A101 = 51: proof of closure function V4. The closed position of valve V4 is monitored by the POC.

Parameter A101 = 52: proof of closure function V5. The closed position of valve V5 is monitored by the POC.

Parameter A101 = 53: tightness test. The pressure switch signal for the tightness test is evaluated.

### 10.11.2 Function of sensor 2

Parameter A102

Terminal 37 is assigned a sensor function using parameter A102.

The value ranges and descriptions for the parameter are identical to parameter A101, see page 89 (Function of sensor 1).

### 10.11.3 Function of sensor 3

Parameter A103

Terminal 38 is assigned a sensor function using parameter A103.

The value ranges and descriptions for the parameter are identical to parameter A101, see page 89 (Function of sensor 1).

### 10.11.4 Proof of closure function test period

Parameter A060

Parameter A060 = 0 to 6000 s: testing time for the closed position of one of the gas valves V1, V2, V3, V4 or V5.

When the start-up signal is received at terminal 1, the BCU checks that one of the gas valves (V1 to V5) is in its closed position using the POC switch. If a signal is not received from the POC switch at terminal 36, 37 or 38, depending on parameter A101, A102 or A103, after the set testing time (gas valve is closed), the BCU performs a fault lock-out with fault message “*E c I*”.

As soon as the BCU has opened the gas valve, it queries the open position of the valve via the POC switch. If a signal is still being received from the POC switch at terminal 36, 37 or 38 after the set testing time, the BCU performs a fault lock-out with fault message “*E c B*”.

## 10.12 Communication

### 10.12.1 Fieldbus communication

Parameter A080

Fieldbus communication can be enabled using parameter A080 when bus module BCM 400 is connected.

A device name/network name must be entered in the automation system/BCSoft for the unique identification of the control unit (BCU/FCU) in the fieldbus system.

Parameter 80 = 0: Off. Fieldbus communication is disabled. Parameterization access using BCSoft via Ethernet is not possible.

Parameter 80 = 1: with address check. The device name/network name on delivery, for example for the BCU 460, is “not-assigned-bcu-460-xxx”. The expression “not-assigned-” must be deleted or may be replaced with an individual name. The sequence xxx must be identical to the address set on the BCM 400 using the code switches (xxx = address in the range 001 to FEF).

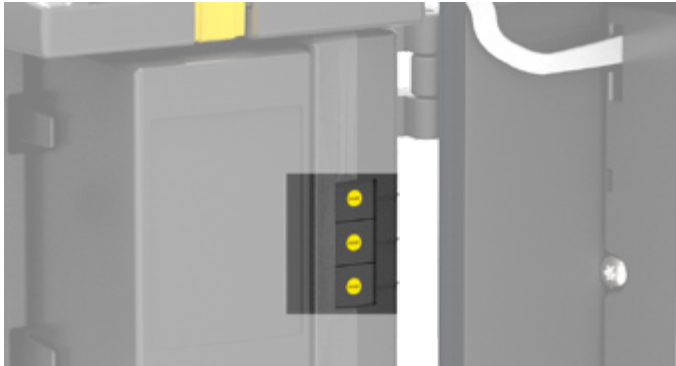

Code switch setting: upper switch (S1) =  $10^2$  (hundreds), centre switch (S2) =  $10^1$  (tens), lower switch (S3) =  $10^0$  (ones)

Parameter 80 = 2: no address check. The device name/network name can be selected as specified by the automation system.

### 10.12.2 K-SafetyLink

Parameter A081

In furnace control systems, consisting of FCU 50x and BCU 46x, the SafetyLink communications protocol is used to transfer safety-critical signals between the FCU and BCU. The data transfer can be enabled using parameter A081.

Parameter A081 = 0: Off. No data exchange takes place via K-SafetyLink.

Parameter A082 = 1: On. Data exchange via K-SafetyLink is enabled. The FCU must support this function.

### 10.12.3 Safety interlocks (bus)

Parameter A085

This parameter defines the interface through which the signal from the safety interlocks is received.

Parameter A085 = 1: via fail-safe bus

Parameter A085 = 2: via terminal

Parameter A085 = 5: via fail-safe bus and terminal

Parameter A089 = 0: Off

Parameter A089 = 1: via fail-safe bus

Parameter A089 = 2: via terminal

Parameter A089 = 5: via fail-safe bus and terminal

### 10.12.4 Purge (bus)

Parameter A087

This parameter defines the interface through which the signal for purging is received.

Parameter A087 = 0: Off

Parameter A087 = 1: via fail-safe bus

Parameter A087 = 2: via terminal

Parameter A087 = 3: via non-fail-safe bus

Parameter A087 = 4: via fail-safe bus or terminal

### 10.12.5 High temperature operation (bus)

Parameter A088

This parameter defines the interface through which the signal for High temperature mode is received.

Parameter A088 = 0: Off

Parameter A088 = 1: via fail-safe bus

Parameter A088 = 2: via terminal

Parameter A088 = 5: via fail-safe bus and terminal

### 10.12.6 LDS (bus)

Parameter A089

This parameter defines the interface through which the LDS signal (limits during start-up) is received.

## 10.13 Interface parameters

**Interface parameters I040 to I099 are set at the factory and normally do not need to be adjusted. Changing the default settings of the interface parameters will change the functions of the inputs at terminals 1 to 41 and terminals 85 to 90, see also page 20 (Connection diagram).**

### 10.13.1 Flame control

Parameter I004

Parameter I004 = 0: flame control is performed with a flame rod.

Parameter I004 = 1: flame control is performed with a UV sensor for intermittent operation (UVS).

Parameter I004 = 2: flame control is performed with a UV sensor for continuous operation (UVC).

Parameter I004 = 3: burner 1 flame control is performed with a flame rod, burner 2 flame control is performed with a UV sensor for intermittent operation (UVS).

Parameter I004 = 4: burner 1 flame control is performed with a flame rod, burner 2 flame control is performed with a UV sensor for continuous operation (UVC).

Parameter I004 = 5: burner 1 flame control is performed with a UV sensor for intermittent operation (UVS), burner 2 flame control is performed with a flame rod.

Parameter I004 = 6: burner 1 flame control is performed with a UV sensor for intermittent operation (UVS), burner 2 flame control is performed with a UV sensor for continuous operation (UVC).

Parameter I004 = 7: burner 1 flame control is performed with a UV sensor for continuous operation (UVC), burner 2 flame control is performed with a flame rod.

Parameter I004 = 8: burner 1 flame control is performed with a UV sensor for continuous operation (UVC), burner 2 flame control is performed with a UV sensor for intermittent operation (UVS).

### Flame control using UV sensors

For intermittent operation, the operating state of the complete system is limited to 24 h pursuant to EN 298. To meet the requirement for intermittent operation, the burner is shut down and restarted automatically after a continuous operating time of 24 hours if it is not operated in compliance with the standard. The restart does not meet the requirements of EN 298 for UV sensor continuous operation because the required self-test (at least once per hour) is not performed while the burner is operating. This shut-down and subsequent restart are performed in the same way as a normal controlled shut-down. Depending on the parameterization, the burner is started with or without pre-purge. This process is controlled independently by the BCU and therefore it must be checked whether the industrial process permits the pause in heat supply it creates.

The reaction times of the BCU and UV sensor for continuous operation are coordinated so that the set safety time during operation (parameter A019) is not extended.

### 10.13.2 Air actuator

Parameter I020

Parameter I020 = 2: IC 40. To ensure that the actuator IC 40 can be operated on the BCU..F1, parameter I020 = 2 (capacity control) must be set. The operating mode of actuator IC 40 may be parameterized to 11 or 27.

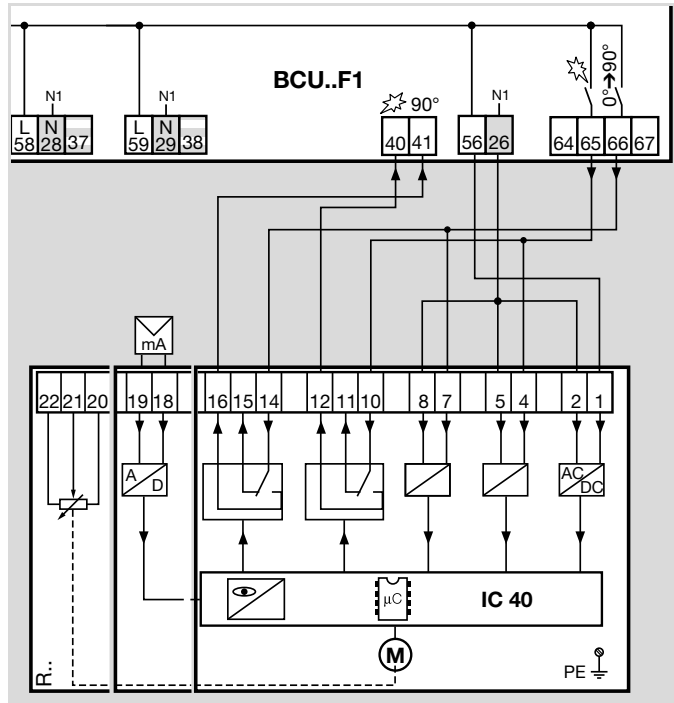

The positions for maximum capacity and ignition capacity can be set using the actuator. Terminal 41 checks whether the position for maximum capacity has been reached. Terminal 40 checks the position for ignition capacity. If the position is not reached within the timeout time of 250 s, a

safety shut-down of the BCU will be performed. A fault message (*E Rc*, *E Ro* or *E Ri*) will be displayed, see page 52 (Fault messages).

If a controller enable is active, the control system is enabled for operation via the outputs at terminals 65 and 66.

### Operating mode 11

Operating mode 11 allows cyclic operation (ON/OFF and OFF/Low/High/OFF).

The actuator IC moves to the “High fire” position during the controller enable procedure. There is no timeout active in this case.

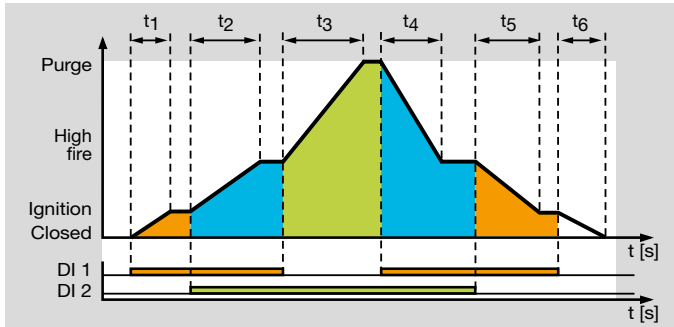

BCU		IC 40 (operating mode 11)	
Signal at terminal		Position	Butterfly valve position
65	66		
OFF	OFF	Closed	Closed
ON	OFF	Ignition	Minimum/Ignition capacity
ON	ON	High-fire rate	High-fire rate
OFF	ON	Purge	Maximum capacity

### Operating mode 27

During the controller enable procedure, the actuator IC 40 can be adjusted infinitely between the positions for maximum and minimum capacity using its analogue input (terminals 18 and 19). There is no timeout active in this case.

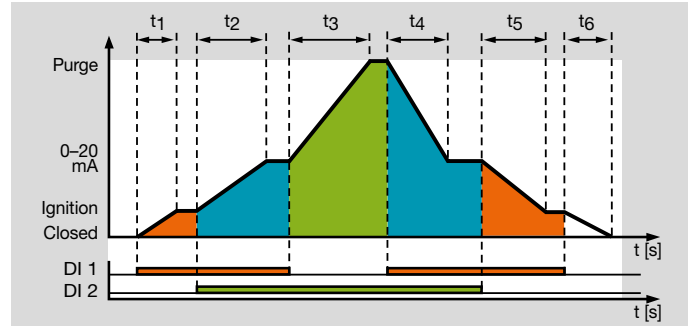

BCU		IC 40 (operating mode 27)	
Signal at terminal		Position	Butterfly valve position
65	66		
OFF	OFF	Closed	Closed
ON	OFF	Ignition	Minimum/Ignition capacity
ON	ON	0-20 mA	Any position between minimum and maximum capacity
OFF	ON	Purge	Maximum capacity

### Fault

In the event of a fault, there will be no signal at terminals 65 and 66 so that the actuator moves to the closed position. When approaching the closed position, no timeout of 250 s is active since no feedback input is checked. This may result in a situation where the program is continued in the case of a request for the closed position, without the butterfly valve being closed. The outputs at terminals 64 (controller enable) and 67 (closed position) on the BCU are non-functional and are not activated.

### Manual mode

In Manual mode, no external controller is enabled. The actuator can be moved to the positions for maximum capacity or ignition capacity by the user. 3-point step operation is not possible. No timeout is active when approaching these positions.

Parameter I020 = 5: air valve. The positions for maximum capacity and ignition capacity can be set using the air valve. If the air valve is closed, the ignition capacity is reached; if it is open, the maximum capacity is reached.

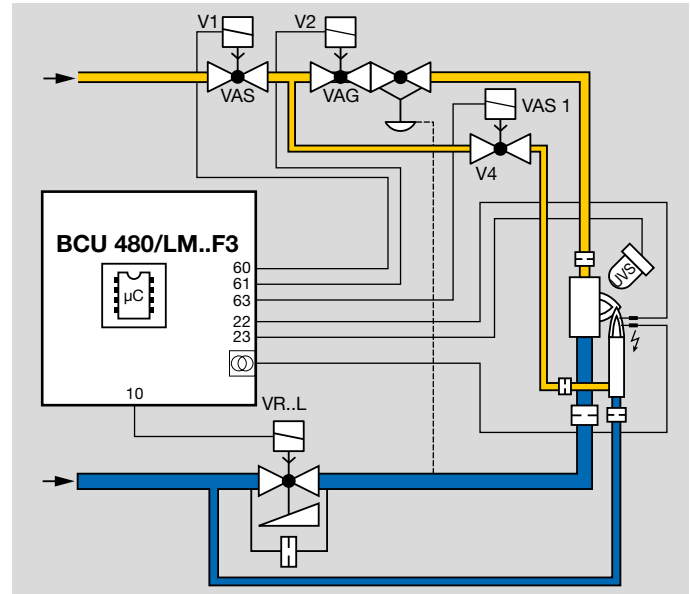

Parameter A042 (Running time) can be used to adjust the behaviour in the case of slow opening and closing air valves, so that the system can be set to ignition position before a start-up is initiated, see page 80 (Running time). Parameter A041 (Running time selection) must be set to 1 to adjust this behaviour.

### **10.13.3 Function of terminal 64**

Parameter I040

Terminal 64 can be assigned a function using parameter I040 depending on the power module LM..F1 or LM..F3. Alternatively, the output can be actuated using a bus system.

Parameter I040 = 0: Off. The output has no function.

Parameter I040 = 2: valve V5. Terminal 64 can be used to activate a fifth valve. This option can only be selected if power module LM..F3 is used.

Parameter I040 = 3: bus output 1. The output at terminal 64 can be actuated using a bus system. Can only be selected with power module LM..F3.

## 10.14 Functions of contacts 80 to 97

Contacts 80 to 97 are floating contacts. They can be parameterized for various signalling functions. The contacts between the relevant terminals close depending on the set function.

### 10.14.1 Contact 80, 81/82 function

Parameter I050

Parameter I050 = 0: Off. The contact will not be closed. It has no function

Parameter I050 = 1: ready signal. The contact is closed if the BCU is ready (switched on) and there is no fault signal.

Parameter I050 = 2: air signal. The air signal is activated as soon as a connected air actuator has reached or exceeded its High position (max. position).

Parameter I050 = 3: purge signal. The contact is closed while purging is active.

Parameter I050 = 4: cooling air valve. The contact is closed if the cooling air valve is to be actuated.

Parameter I050 = 6: fault signal. The contact is closed if a fault lock-out is active.

Parameter I050 = 7: burner 1 operating signal. The contact is closed if burner 1 is in operation.

Parameter I050 = 8: burner 2 operating signal. The contact is closed if burner 2 is in operation.

### 10.14.2 Contact 90, 91/92 function

Parameter I051

For a description and the parameter values, see page 97 (Contact 80, 81/82 function).

### 10.14.3 Function of contact 95/96

Parameter I052

For a description and the parameter values, see page 97 (Contact 80, 81/82 function).

### 10.14.4 Function of contact 95/97

Parameter I053

For a description and the parameter values, see page 97 (Contact 80, 81/82 function).

### 10.14.5 Contact 85/86, 87 function

Parameter I054

For a description and the parameter values, see page 97 (Contact 80, 81/82 function).

## 10.15 Functions of inputs at terminals 1 to 7 and 35 to 41

The BCU has multiple physical and logical interfaces to receive its input signals and set output signals. Parameters I061 to I074 are used to define which input signals can be received at the various terminals (1 to 7 and 35 to 41).

Sensors (pressure switches and POC switches) can be connected to inputs 36, 37 and 38 depending on the parameter setting.

### BCU..E0

Input 35 is reserved for the safety interlock function. All other inputs can also be parameterized for the safety interlock function (I061 = 4).

#### 10.15.1 Function of input 1

Parameter I061

To define the input signal for terminal 1.

Parameter I061 = 0: Off. The input has no function.

Parameter I061 = 4: safety interlocks. The “safety interlocks” signal can be applied via the input and/or SafetyLink. No start-up is commenced if there is no signal at the input. If the signal drops out during operation, the gas valves are closed immediately (< 1 s).

Parameter I061 = 5: air. The BCU receives the signal for controlled air flow or for external air actuator control through the input.

Parameter I061 = 6: cooling air. The BCU receives the signal to actuate the cooling air actuator through the input.

Parameter I061 = 7: air actuator R1. The BCU receives the feedback signal for the ignition position from actuator IC 40 through the input.

Parameter I061 = 8: air actuator R2. The BCU receives the feedback signal for the High position from actuator IC 40 through the input.

Parameter I061 = 9: start 1. The BCU receives the start-up signal for the pilot burner (start 1) through the input.

Parameter I061 = 10: start 2. The BCU receives the start-up signal for the main burner (start 2) through the input.

Parameter I061 = 11: reset. The BCU receives the signal for a remote reset through the input.

Parameter I061 = 12: purge. The BCU receives the purge signal through the input.

Parameter I061 = 13: LDS. The BCU does not perform a burner start-up, restart or start-up attempt until the central actuator is in ignition position, see the application example on page 11 (Modulating control with defined ignition position). To ensure that the burners only start with the start fuel flow rate, the higher-level control system sends a signal to start the burner through the terminal to the BCU.

Parameter I061 = 14: high temperature operation. This input is used to signal to the burner control unit that the furnace system is in High temperature mode (HT). The burner control unit switches to High temperature mode when the HT input is activated. It operates without evaluating the flame signal and its internal flame control system is non-functional.

#### 10.15.2 Function of input 2

Parameter I062

To define the input signal for terminal 2.

For parameter values and descriptions, see page 98 (Function of input 1).

### 10.15.3 Function of input 3

Parameter I063

To define the input signal for terminal 3.

For parameter values and descriptions, see page 98 (Function of input 1).

### 10.15.4 Function of input 4

Parameter I064

To define the input signal for terminal 4.

For parameter values and descriptions, see page 98 (Function of input 1).

### 10.15.5 Function of input 5

Parameter I065

To define the input signal for terminal 5.

For parameter values and descriptions, see page 98 (Function of input 1).

### 10.15.6 Function of input 6

Parameter I066

To define the input signal for terminal 6.

For parameter values and descriptions, see page 98 (Function of input 1).

### 10.15.7 Function of input 7

Parameter I067

To define the input signal for terminal 7.

For parameter values and descriptions, see page 98 (Function of input 1).

### 10.15.8 Function of input 35

Parameter I068

To define the input signal for terminal 35.

On a BCU..E1 (power supply via L1), this input should be reserved for the safety interlock signal (I068 = 4). On a BCU..E0, this input is connected to the power supply for the safety-relevant outputs and cannot be parameterized otherwise. For all other parameter values and descriptions, see page 98 (Function of input 1).

### 10.15.9 Function of input 36

Parameter I069

To define the input signal for terminal 36.

A sensor may be connected to this input (I069 = 1, 2 or 3) if necessary.

Parameter I069 = 1: sensor 1

Parameter I069 = 2: sensor 2

Parameter I069 = 3: sensor 3

For all other parameter values and descriptions, see page 98 (Function of input 1)

### 10.15.10 Function of input 37

Parameter I070

To define the input signal for terminal 37.

A sensor may be connected to this input (I070 = 1, 2 or 3) if necessary.

Parameter I070 = 1: sensor 1

Parameter I070 = 2: sensor 2

Parameter I070 = 3: sensor 3

For all other parameter values and descriptions, see page 98 (Function of input 1).

### **10.15.11 Function of input 38**

Parameter I071

To define the input signal for terminal 38.

A sensor may be connected to this input (I071 = 1, 2 or 3) if necessary.

Parameter I071 = 1: sensor 1

Parameter I071 = 2: sensor 2

Parameter I071 = 3: sensor 3

For all other parameter values and descriptions, see page 98 (Function of input 1).

### **10.15.12 Function of input 39**

Parameter I072

To define the input signal for terminal 39.

For parameter values and descriptions, see page 98 (Function of input 1).

### **10.15.13 Function of input 40**

Parameter I073

To define the input signal for terminal 40.

For parameter values and descriptions, see page 98 (Function of input 1).

### **10.15.14 Function of input 41**

Parameter I074

To define the input signal for terminal 41.

For parameter values and descriptions, see page 98 (Function of input 1).

## 11 Replacement possibilities

Burner control units BCU 480 can be replaced by the next-generation devices BCU 480 (2019).

By comparison to the previous generation, the next-generation BCU 4 (2019) units feature new technologies and functions which can be freely parameterized.

Code	Description of BCU (previous generation)	Description of BCU	Code
BCU	Burner control unit		
4	Series 4	Series 4 burner control unit	BCU 4
80	Version for pilot and main burners	Series 480	80
3; 5; 10	1 <sup>st</sup> safety time on start-up $t_{SA}$ [s]	Can be adjusted using parameter A094: 2 to 15 s	•
/3; /5	2 <sup>nd</sup> safety time on start-up $t_{SA}$ [s]	Can be adjusted using parameter A096: 2 to 15 s	•
1; 2	Safety time during operation $t_{SB}$ [s]	Can be adjusted using parameter A019: 0, 1, 2, 3, 4 s	•
L1)	Air valve control	In conjunction with LM..F1 = with IC 40 interface LM 400..F3 = with air valve control	o
51); 151); 251)	Low fire over-run time [s]	Can be adjusted using parameter A039 (Over-run time): 0 to 60 s	•
W R	Mains voltage: 230 V AC, -15/+10%, 50/60 Hz 115 V AC, -15/+10%, 50/60 Hz	Mains voltage: 230 V AC, -15/+10%, 50/60 Hz 120 V AC, -15/+10%, 50/60 Hz	W Q
1) 2) 3) 8)	Ignition transformer: TZI 5-15/100 TZI 7-25/20 TZI 7,5-12/100 TZI 7,5-20/33	Ignition transformer: 5 kV, 15 mA, 100% duty cycle 8 kV, 20 mA, 19% duty cycle 8 kV, 12 mA, 100% duty cycle 8 kV, 20 mA, 33% duty cycle	1 2 3 8
GB1)	Front film in English with additional stickers in D, F, I, NL, E	Set of language stickers in GB, F, NL, I, E, see accessories	o
P1)	Industrial plug connector	Flange plate: none standard M32 industrial plug connector, 16-pin PROFIBUS conduit	P0 P1 P2 P3 P6 P7
	-	No valve proving system With TC and POC valve proving system With POC valve proving system	C0 C1 C2
D21) D31)	High temperature operation in conjunction with: ... UVS ... ionization or UVD	No high temperature operation For high temperature operation	D0 D1
S2-31)	Number of start-up attempts, pilot burner	Can be adjusted using parameter A007: 1, 2 or 3	•
/2-31)	Number of start-up attempts, main burner	Can be adjusted using parameter A008: 1, 2 or 3	•

## Replacement possibilities

Code	Description of BCU (previous generation)		Description of BCU	Code
A <sup>1)</sup> O <sup>1)</sup>	Air flow monitoring POC switch feedback		Pressure switches: none air pressure switches gas pressure switches air and gas pressure switches	0 1 2 3
U <sup>1)</sup> C <sup>1)</sup> 3)	Preparation for UV sensor for continuous operation UVD 1 Additional signal distribution		Flame control can be adjusted using parameter I004: ionization, UVS or UVC	•
B1 <sup>1)</sup>	For PROFIBUS DP		With optional bus module: BCM 400..B1 for PROFIBUS BCM 400..B2 for PROFINET BCM 400..B3 for EtherNet/IP	o
/1 <sup>1)</sup>	9-pin D-Sub bus plug connector		With bus module BCM 400..B1: 9-pin D-Sub connector With bus module BCM 400..B2/B3: two RJ45 sockets	o
E <sup>1)</sup> 4)	Power management: via safety interlock input via phase (L1)		Energy supply: via safety interlock input via phase (L1)	E0 E1

• = standard, o = available.

1) If "none", this specification is omitted.

2) Complete type codes and selection tables for the next-generation BCU 4 and power module LM 400, see page 103 (Selection).

3) BCU..C with additional PCB for voltage distribution to the UV sensor for continuous operation. Can be used as a sub-distribution board due to the low number of outputs. The new BCU 4 (2019) has an adequate number of (parameterizable) inputs and outputs as well as contacts. When making the replacement, check whether the additional sub-distribution board is still required.

4) If power management is implemented using the safety interlocks, this specification is omitted. E1 = power management via phase (L1).

## 12 Selection

### 12.1 Burner control unit BCU

Option	BCU
Series	480
Mains voltage	Q, W
Ignition transformer	1, 2, 3, 8
Flange plate	P0, P1, P2, P3, P6, P7
Valve proving system	C0, C1, C2
High temperature operation	D0, D1
Input functions	0, 2
Pressure switches	0
Connection plugs	K0, K1, K2
Energy supply	E0, E1

#### Order example

BCU 480W2P1C1D00K1E1

## Selection

### 12.1.1 Type code

<b>BCU</b>	Burner control unit
<b>4</b>	Series 400
<b>60</b>	Standard version
<b>65</b>	Extended air control
<b>80</b>	Version for pilot and main burners
<b>Q</b>	Mains voltage: 120 V AC, 50/60 Hz
<b>W</b>	Mains voltage: 230 V AC, 50/60 Hz
<b>0</b>	No ignition transformer
<b>1</b>	Ignition transformer, 5 kV, 15 mA, 100% duty cycle
<b>2</b>	Ignition transformer, 8 kV, 20 mA, 19% duty cycle
<b>3</b>	Ignition transformer, 8 kV, 12 mA, 100% duty cycle
<b>8</b>	Ignition transformer, 8 kV, 20 mA, 33% duty cycle
<b>P0</b>	No flange plate
<b>P1</b>	Flange plate: standard
<b>P2</b>	Flange plate: M32
<b>P3</b>	Flange plate: 16-pin industrial plug connector
<b>P6</b>	Flange plate: PROFIBUS
<b>P7</b>	Flange plate: conduit
<b>C0</b>	No valve proving system
<b>C1</b>	Valve proving system: TC and POC
<b>C2</b>	Valve proving system: POC
<b>D0</b>	No high temperature operation
<b>D1</b>	High temperature operation
<b>D2</b>	Flameless operation
<b>0</b>	No input function
<b>1</b>	Input function: auxiliary gas
<b>2</b>	Input function: LDS

<b>3</b>	Input function: auxiliary gas and LDS
<b>0</b>	No pressure switches
<b>1</b>	Air pressure switches
<b>2</b>	Gas pressure switches
<b>3</b>	Pressure switches for gas and air
<b>K0</b>	No connection plugs
<b>K1</b>	Connection plugs with screw terminals
<b>K2</b>	Connection plugs with spring force terminals
<b>E</b>	Individual packaging
<b>S</b>	Bulk packaging
<b>E0</b>	Energy supply: via safety interlocks
<b>E1</b>	Energy supply: via L1

## 12.2 Power module LM 400

Option	LM
Series	400
Mains voltage	Q, W
Air actuator	F0, F1, F3
Optional output	O0, O1, O2
Energy supply	E0, E1
Connection plugs	K0, K1, K2

### Order example

LM 400WF1O0E1K1

#### 12.2.1 Type code

<b>LM</b>	Power module
<b>400</b>	Series 400
<b>Q</b>	Mains voltage: 120 V AC, 50/60 Hz
<b>W</b>	Mains voltage: 230 V AC, 50/60 Hz
<b>F0</b>	Air actuator: none
<b>F1</b>	Air actuator: with IC 40 interface
<b>F3</b>	Air actuator: with air valve control
<b>O0</b>	Optional output: none
<b>O1</b>	Optional output: not fail-safe
<b>O2</b>	Optional output: fail-safe
<b>E0</b>	Energy supply: via safety interlocks
<b>E1</b>	Energy supply: via L1

## 13 Project planning information

### 13.1 Installation

Installation position: vertical (cable glands pointing downwards) or down flat.

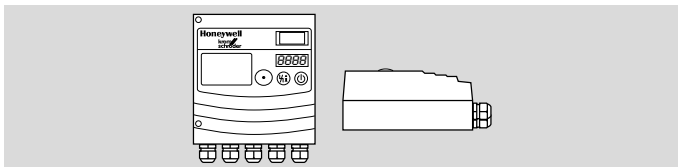

Distance between BCU and burner: recommended < 1 m (3.3 ft), max. 5 m (16.4 ft).

When installing, ensure that there is sufficient space to open the BCU.

#### Securing the device from inside

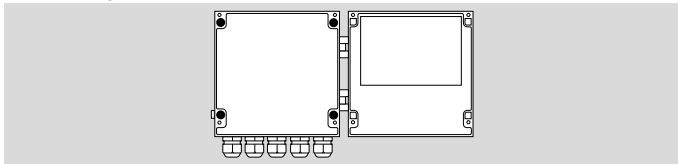

Screw on the BCU with four screws, Ø 4 mm, min. length 15 mm.

#### Securing the device from outside

The unit remains closed.

Attach the BCU using four self-tapping screws (M6 x 20 mm, supplied with the unit).

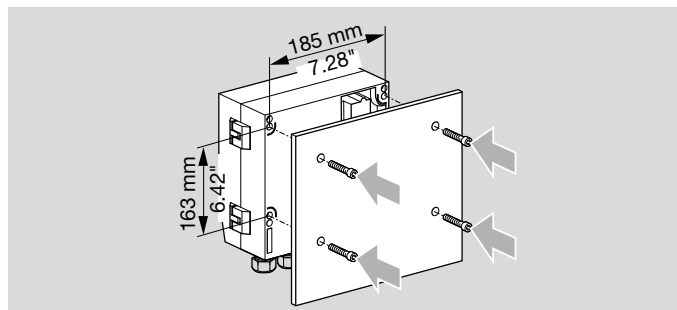

For other mounting options using a fastening set or external securing bars, see page 111 (Fastening set) or page 111 (External securing bars).

### 13.2 Commissioning

Do not start the BCU until the parameter settings and wiring are correct and the faultless processing of all input and output signals complies with the local standards.

### 13.3 Electrical connection

The BCU is designed for connection to a 1-phase system. All inputs and outputs have a one-phase mains supply. Other connected burner control units must use the same phase of the mains supply.

The national standards and safety requirements must be satisfied. If the BCU is operated in ungrounded/IT systems, an insulation monitoring device must be provided to isolate it from the mains in the event of a fault. The cabling of the safety circuits (e.g. pressure switches, gas valves) outside enclosed installation spaces must be protected from mechanical damage and stress (e.g. vibration or bending) as well as short-circuits, short-circuits to ground and cross-circuits.

Signal and control line for screw terminals max. 2.5 mm<sup>2</sup> (AWG 12), for spring force terminals max. 1.5 mm<sup>2</sup> (AWG 16).

Do not route BCU cables in the same cable duct as frequency converter cables or cables emitting strong fields. External electrical interference must be avoided.

#### 13.3.1 Safety current inputs

Actuation of the safety current inputs only with switchgear featuring mechanical contacts. If switchgear with semiconductor contacts is used, the safety current inputs must be connected using relay contacts.

To safeguard the safety current inputs, the fuse must be designed so that the sensor with the lowest switching capacity is protected.

The cabling outside enclosed installation spaces must be protected from mechanical damage and stress (e.g. vibra-

tion or bending) as well as short-circuits, short-circuits to ground and cross-circuits.

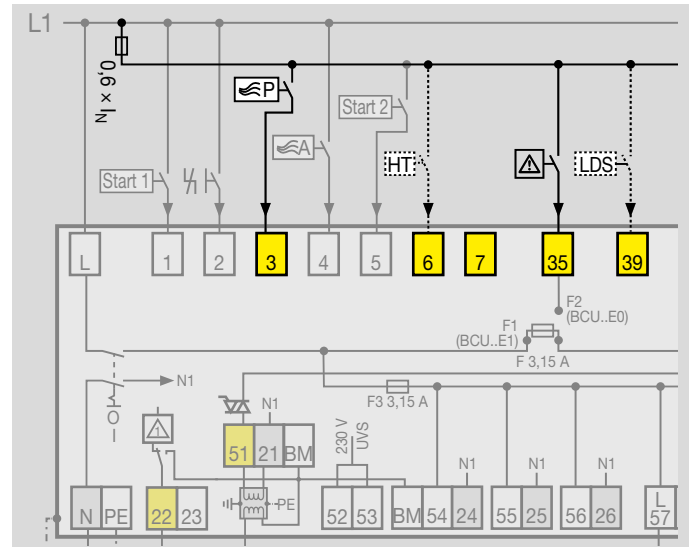

#### Calculation

$I_N$  = current of the sensor/contactors with the lowest switching capacity

Suitable fuse =  $0.6 \times I_N$

### 13.4 Actuators

If actuators are used, the start gas rate of the burners must be limited for SIL 3 applications in compliance with the standard.

### 13.5 Parameter chip card

The parameter chip card must be installed in the unit for the BCU to operate. The parameter chip card contains the valid parameter settings for the BCU. If a BCU is replaced, the parameter chip card can be removed from the old unit and inserted into the new BCU. The BCU must be disconnected from the electrical power supply for this purpose. The valid parameters are then adopted by the new BCU. The old device and the new BCU must have an identical type code.

### 13.6 K-SafetyLink

In furnace control systems, consisting of FCU and BCU 4, the SafetyLink communications protocol is used to transfer safety-critical signals between the FCU and BCU. The data transfer can be enabled using parameter A081. The FCU must support the function for communicating via K-SafetyLink.

### 13.7 Overload protection

To protect the unit against overload by frequent cycling, only a specific number of start-up attempts can be carried out by the BCU. The maximum number of start-up attempts per minute depends on the safety time  $t_{SA}$  and the ignition time  $t_z$ .

t [s]	Device type		Max. number [n/min.]
	Ignition	transformer ID number	
3	BCU..Q1 34340581	BCU..W1 34340585	6
5	BCU..Q1 34340581	BCU..W1 34340585	6
10	BCU..Q1 34340581	BCU..W1 34340585	3
3	BCU..Q2 34340582	BCU..W2 34340586	3
5	BCU..Q2 34340582	BCU..W2 34340586	2
10	BCU..Q2 34340582	BCU..W2 34340586	1
3	BCU..Q3 34340583	BCU..W3 34340587	6
5	BCU..Q3 34340583	BCU..W3 34340587	4
10	BCU..Q3 34340583	BCU..W3 34340587	2
3	BCU..Q8 34340584	BCU..W8 34340588	4
5	BCU..Q8 34340584	BCU..W8 34340588	3
10	BCU..Q8 34340584	BCU..W8 34340588	2

If too many start-up attempts are made, 53 flashes on the display to indicate a fault.

## **13.8 Calculating the safety time $t_{SA}$**

See [www.adlatus.org](http://www.adlatus.org)

## 14 Accessories

### 14.1 High-voltage cable

FZLSi 1/7 -50°C (-58°F) to +180°C (+356°F),

Order No.: 04250410,

FZLK 1/7 -5°C (23°F) to +80°C (176°F),

Order No.: 04250409.

### 14.2 Industrial plug connector, 16-pin



Order No.: 74919469

### 14.3 BCSoft4

The current software can be downloaded from our Internet site at [www.docuthek.com](http://www.docuthek.com). To do so, you need to register in the DOCUTHEK.

### 14.3.1 Opto-adapter PCO 200



Including BCSoft CD-ROM,

Order No.: 74960625.

### 14.4 Connection plug set

For wiring the BCU.

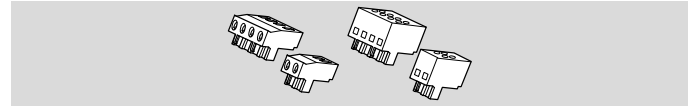

Connection plugs with screw terminals,

Order No.: 74924876.

Connection plugs with spring force terminals, 2 connection options per terminal,

Order No.: 74924877.

## 14.5 Set of language stickers

To affix to the cover, with program step/fault message descriptions in English, French, Dutch, Spanish and Italian, on request.

## 14.6 Fastening set

To ensure a gap between the BCU and the mounting surface with higher temperatures.

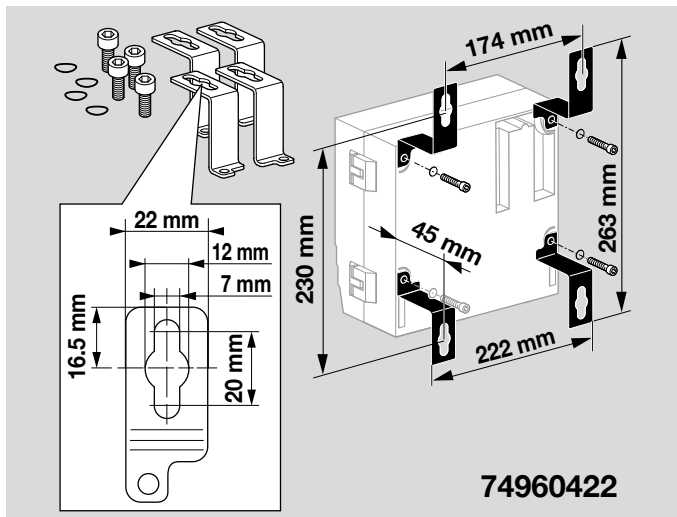

## 14.7 External securing bars

The external securing bars are screwed on from inside the unit.

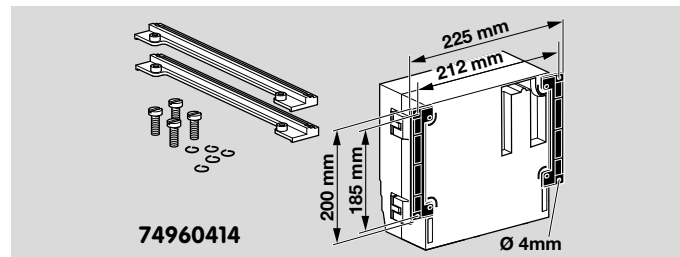

## 14.8 Bus module BCM 400

Communication interface for connecting the BCU to an automation system.



BCM 400..B1



BCM 400..B2, BCM 400..B3

Bus module	Bus system	Order No.
BCM 400S0B3/3-0	EtherNet/IP	74960692

Bus module	Bus system	Order No.
BCM 400S0B1/1-0	PROFIBUS	74960690
BCM 400S0B2/3-0	PROFINET	74960691

## 14.9 Flange plates

For improved cable routing to ensure simple installation/removal of the BCU. Depending on the version, also with pre-wired connection plugs for PROFIBUS or 16-pin industrial plug connector.

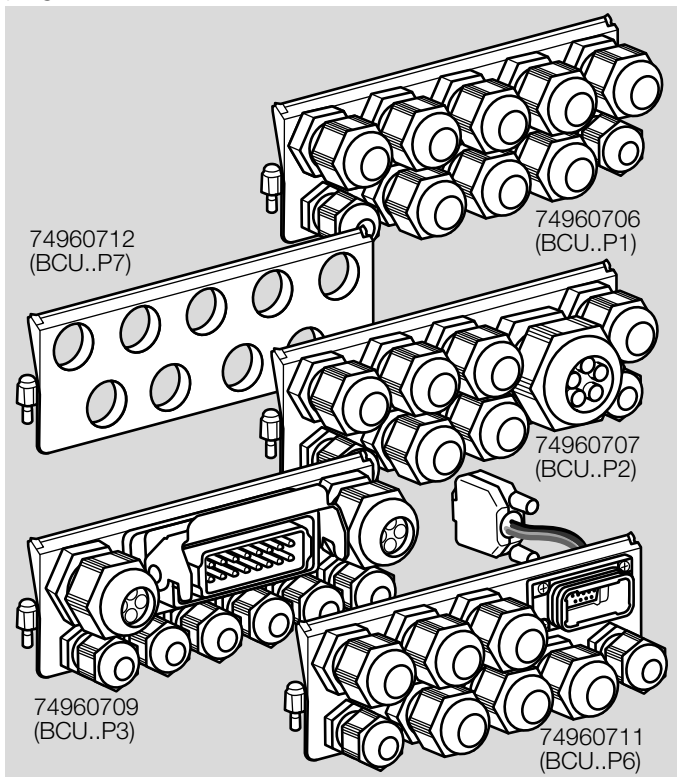

Order No.	Version	Description
74960707 <sup>1)</sup>	M32 (BCU..P2)	1 x M32, 6 x M20, 2 x M16 cable glands
74960709	16-pin plug, wired (BCU..P3)	1 x 16-pin industrial plug, 2 x M25, 6 x M16 cable glands
74960711 <sup>2)</sup>	PROFIBUS plug, wired (BCU..P6)	1 x PROFIBUS plug, 6 x M20, 2 x M16 cable glands
74960712	Conduit (BCU..P7)	With boreholes for conduit connections

1) Recommended for PROFINET or Ethernet.

2) Recommended for replacement of a previous version of the BCU for PROFIBUS. The PROFIBUS plug is identical.

Order No.	Version	Description
74960706	Standard (BCU..P1)	8 x M20, 2 x M16 cable glands

## 15 BCM 400

For further information on the electrical connection, commissioning and installation, see operating instructions for BCM 400..B1 or BCM 400..B2/B3 at [www.docuthek.com](http://www.docuthek.com).

### 15.1 Application



The bus module BCM 400 is used as a communication interface for devices of the BCU 4 (2019) product family for connection to a fieldbus communications system (PROFIBUS, PROFINET or EtherNet/IP). Networking via the fieldbus enables the BCU to be controlled and monitored by an automation system (e.g. PLC).

### 15.2 Function

The bus system transfers the control signals for starting, re-setting and for controlling the air valve to purge the furnace or kiln or for cooling in start-up position and heating during operation from the automation system (PLC) to the BCM. In the opposite direction, it sends operating status, the level of the flame signal and the current program step.

### 15.3 Electrical connection

Use only cable and plug components which comply with the relevant PROFIBUS, PROFINET or EtherNet/IP specifications.

Cable length between 2 fieldbus subscribers: max. 100 m (328 ft).

Installation of the communications network pursuant to IEC 61918.

Protect the communications network against unauthorized access.

#### BCM..B1

Wire control signals that are relevant for safety, such as the safety interlocks and digital input, separately.

The purge signals can be transferred via the bus communication or by a separate cable via terminal.

To connect the BCM..B1 to the PROFIBUS fieldbus communications system, use an RS 485 9-pin PROFIBUS plug connector with a deactivatable bus terminator and axial cable routing, e.g. 6GK1500-0FC00 or 6GK1500-0EAO2 from Siemens. If other connectors are used, ensure that metal parts are adequately grounded.

BCU..P6: for connection to the BCU mounting plate, use only a 9-pin Variosub PROFIBUS plug connector with a deactivatable bus terminator,

Order No. 74960431.



### Installation guidelines

For PROFIBUS, PROFINET, see [www.profibus.com](http://www.profibus.com),  
for Ethernet, see [www.odva.org](http://www.odva.org).

Data cables A and B must not be reversed.

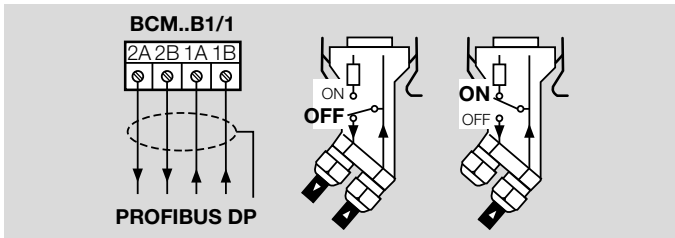

Connect the shield on both sides and over a wide area with shield clips in the plug.

Switch on the terminal resistors on the first and last subscriber in the segment.

The power supply for the bus terminator is provided by the BCU. The bus terminator can be activated in the PROFIBUS plug connector.

Ensure there is an equipotential bond between the devices.

### BCM..B2/B3

Use shielded RJ45 plugs.

## 15.4 Commissioning

### BCM..B1

Fieldbus communication can be configured using the engineering tool of the automation system.

All the device-specific parameters for the BCM..B1 are saved in a device master data file (GSD)/electronic data sheet (EDS): download from [www.docuthek.com](http://www.docuthek.com).

The BCM..B1 will automatically identify the baud rate – max. 1.5 Mbit/s. The max. range per segment depends on the baud rate:

Baud rate [kbit/s]			
93.75	187.5	500	1500
Range [m (ft)]			
1200 (3937)	1000 (3280)	400 (1312)	200 (656)

The ranges can be increased by using repeaters. No more than three repeaters should be connected in series.

### BCM..B2/B3

Depending on the bus module version (BCM..B2 or BCM..B3), fieldbus communication can be configured using the engineering tool of the automation system or using BCSofT. BCM..S1 can only be commissioned using BCSofT.

Check the code switch settings (001 to 125) on the BCM for PROFIBUS communication between BCSofT and the control unit.

Each code switch setting combination may only exist once within the fieldbus system.

Each device name/network name may only be allocated once within the fieldbus system.

**BCU..B2:** all the device-specific parameters for the control unit (BCU) are saved in the device master data file (GSD). Download from [www.docuthek.com](http://www.docuthek.com).

**BCU..B3:** all the device-specific parameters for the control unit (BCU) are saved in the electronic data sheet file (EDS). Download from [www.docuthek.com](http://www.docuthek.com).

## 15.5 Installation

Insert the bus module in the slot provided and set parameter A080.

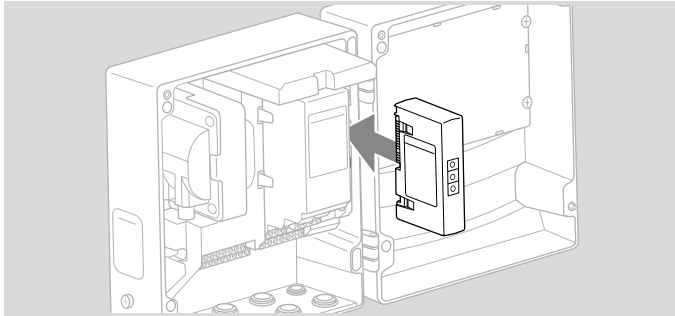

## 15.6 Selection

BCM	Bus module
400	Series 400
S0	Standard communication
S1	SafetyLink
B1	PROFIBUS DP <sup>1)</sup>
B2	PROFINET <sup>2)</sup>
B3	EtherNet/IP <sup>3)</sup>
/1	9-pin D-Sub
/3	Two RJ45 sockets
-0	–
-3	Three-point step control via bus

1) Order No.: 74960690

2) Order No.: 74960691

3) Order No.: 74960692

## 15.7 Technical data

### Electrical data

Power consumption: 1.2 VA.

Power loss: 0.7 W.

### Mechanical data

Dimensions (W × H × D):

96 × 63 × 23 mm (3.78 × 2.48 × 0.91 inches).

Weight: 0.3 kg.

### Ambient conditions

Avoid direct sunlight or radiation from red-hot surfaces on the unit.

Avoid corrosive influences, e.g. salty ambient air or SO<sub>2</sub>.

The unit may only be stored/installed in enclosed rooms/buildings.

This unit is not suitable for cleaning with a high-pressure cleaner and/or cleaning products.

Ambient temperature:

-20 to +70°C (-4 to +158°F),  
no condensation permitted.

Enclosure: IP 20 pursuant to IEC 529.

Installation location: min. IP 65 (for installation in BCU 4xx).

Permitted operating altitude: < 2000 m AMSL.

## 16 Technical data

### 16.1 Electrical data

Mains voltage:

BCU..Q: 120 V AC, -15/+10%, 50/60 Hz,  $\pm 5\%$ ,  
BCU..W: 230 V AC, -15/+10%, 50/60 Hz,  $\pm 5\%$ .

Power consumption: 10 VA,  
for grounded and ungrounded mains.

Flame control:

with UV sensor or flame rod.

For intermittent or continuous operation.

Flame signal current:

Ionization control: 1–25 A,

UV control: 1–35 A.

Ionization cable, UV cable:  
max. 50 m (164 ft).

Contact rating:

Valve outputs V1, V2, V3 and V4 (terminals 60, 61, 62, 63 and 64): max. 1 A each,  $\cos \varphi = 1$ .

Actuator outputs (terminals 65, 66 and 67): max. 1 A each,  
 $\cos \varphi = 1$ .

Air valve output (terminal 65): max. 1 A,  $\cos \varphi = 1$ .

Ignition transformer (terminal 51): max. 2 A.

Total current for the simultaneous activation of the valve outputs (terminals 60, 61, 62, 63 and 64) and of the ignition transformer (terminal 51), protected by F1/F2: max. 2.5 A.

Total current for the simultaneous activation of the outputs for air valve and actuator (terminals 65, 66 and 67): max. 2 A.

Signalling contact for operating and fault signals:  
max. 1 A at  $\cos \varphi = 1$  (external fuse required).

Number of operating cycles: The fail-safe outputs (valve outputs V1, V2, V3 and V4) and the air valve output are monitored for correct functioning and are thus not subject to a max. number of operating cycles.

Control actuator (terminals 60, 61, 62, 63 and 64):

1,000,000,

signalling contact for operating signals (terminals 95, 96 and 97):

1,000,000,

signalling contact for fault signals (terminals 80, 81 and 82):

max. 25,000,

On/Off button:

max. 10,000,

Reset/Information button:

max. 10,000.

Input voltage of signal inputs:

Rated value	120 V AC	230 V AC
Signal "1"	80–132 V	160–253 V
Signal "0"	0–20 V	0–40 V

Signal input current:

Signal "1"	max. 5 mA
------------	-----------

Fuses, replaceable, F1/F2/F3: T 3.15A H,  
pursuant to IEC 60127-2/5.

Does not meet the requirements for safety extra-low voltage (SELV/PELV).

## Ignition transformer

Burner control unit	Ignition transformer (material No.)	Input			Output	
		V AC	Hz*	A*	V AC	mA*
BCU..W1	TRS515PCISOH2 (34340585)	230	50 (60)	0.4 (0.3)	5000	15 (10)
BCU..Q1	TRS515PCISOH1 (34340581)	120	50 (60)	0.9 (0.6)	5000	15 (11)
BCU..W2	TRE820PISOH2 (34340586)	230	50 (60)	1.0 (0.7)	8000	20 (16)
BCU..Q2	TRE820PISOH1 (34340582)	120	50 (60)	1.9 (1.4)	8000	20 (16)
BCU..W3	TRS812PCISOH2 (34340587)	230	50 (60)	0.6 (0.4)	8000	12 (9)
BCU..Q3	TRS812PCISOH1 (34340583)	120	50 (60)	1.2 (0.9)	8000	12 (9)
BCU..W3	TRS820PISOH2 (34340587)	230	50 (60)	1.0 (0.7)	8000	20 (16)
BCU..Q3	TRS820PISOH1 (34340583)	120	50 (60)	1.7 (1.3)	8000	20 (16)

\* Values in brackets apply to 60 Hz.

## 16.2 Mechanical data

Weight: 5.5 kg.

Dimensions (W x H x D): 200 x 230 x 135 mm.

Connections:

Screw terminals:

nominal cross-section 0.2 mm<sup>2</sup>,

wire cross-section (rigid) min. 0.2 mm<sup>2</sup>,

wire cross-section (rigid) max. 2.5 mm<sup>2</sup>,

wire cross-section AWG/kcmil min. 24,

wire cross-section AWG/kcmil max. 12.

Spring force terminals:

nominal cross-section 2 x 1.5 mm<sup>2</sup>,

wire cross-section min. 0.2 mm<sup>2</sup>,

wire cross-section AWG min. 24,

wire cross-section AWG max. 16,

wire cross-section max. 1.5 mm<sup>2</sup>.

## 16.3 Ambient conditions

Avoid direct sunlight or radiation from red-hot surfaces on the unit.

Avoid corrosive influences, e.g. salty ambient air or SO<sub>2</sub>.

The unit may only be stored/installed in enclosed rooms/buildings that are not accessible to the public.

This unit is not suitable for cleaning with a high-pressure cleaner and/or cleaning products.

Ambient temperature:

-20 to +70°C (-4 to +158°F),

no condensation permitted.

Enclosure: IP 65 pursuant to IEC 529.

Safety class: 1.

Pollution degree: internal environment: 2, external environment: 4.

Permitted operating altitude: < 2000 m AMSL.

## 16.4 Dimensions

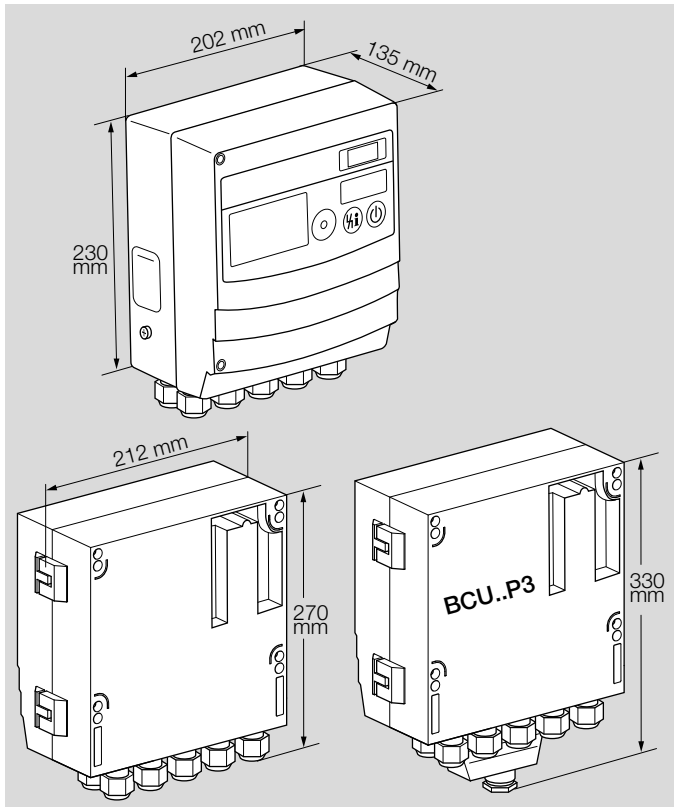

## **17 Converting units**

See [www.adlatus.org](http://www.adlatus.org)

## 18 Safety-specific characteristic values for SIL and PL

Certificates – see [www.docuthek.com](http://www.docuthek.com).

For systems up to SIL 3 pursuant to EN 61508.

Pursuant to EN ISO 13849-1:2006, the BCU can be used up to PL e.

Suitable for Safety Integrity Level	Up to SIL 3
Diagnostic coverage DC	91.3%
Type of subsystem	Type B to EN 61508-2:2010
Mode of operation	High demand mode pursuant to EN 61508-4:2010
Mean probability of dangerous failure PFH <sub>D</sub>	32.9 × 10 <sup>-9</sup> 1/h on BCU 4xx..F1, 38.3 × 10 <sup>-9</sup> 1/h on BCU 4xx..F3
Mean time to dangerous failure MT-TF <sub>d</sub>	MTTF <sub>d</sub> = 1/PFH <sub>D</sub>
Safe failure fraction SFF	99.0%

### Mean probability of dangerous failure PFH<sub>D</sub> of individual safety functions

Burner control with 2 gas valves	23.2 × 10 <sup>-9</sup> 1/h
Burner control with 3 gas valves	28.5 × 10 <sup>-9</sup> 1/h
Valve check	15.0 × 10 <sup>-9</sup> 1/h
Proof of closure	3.3 × 10 <sup>-9</sup> 1/h
Flame control	8.4 × 10 <sup>-9</sup> 1/h
Temperature monitoring	2.2 × 10 <sup>-9</sup> 1/h
Air pressure switch monitoring	3.3 × 10 <sup>-9</sup> 1/h
Gas pressure switch monitoring	3.3 × 10 <sup>-9</sup> 1/h
Purge with air pressure switch	4.3 × 10 <sup>-9</sup> 1/h
K-SafetyLink	1.0 × 10 <sup>-9</sup> 1/h
Safety interlocks (limits)	2.2 × 10 <sup>-9</sup> 1/h
Valve check with redundant pressure switch	12.9 × 10 <sup>-9</sup> 1/h
Air pressure switch monitoring with red. pressure switch	1.3 × 10 <sup>-9</sup> 1/h
Gas pressure switch monitoring with red. pressure switch	1.3 × 10 <sup>-9</sup> 1/h
Purge with red. air pressure switch	2.3 × 10 <sup>-9</sup> 1/h

### Relationship between the Performance Level (PL) and the Safety Integrity Level (SIL)

PL	SIL
a	–
b	1
c	1
d	2
e	3

Max. service life under operating conditions:  
10 years after date of production.

For a glossary of terms, see page 127 (Glossary).

## 19 Safety information in accordance with EN 61508-2

### 19.1 General

#### Scope of application

as set out in “Industrial thermoprocessing equipment – Part 2: Safety requirements for combustion and fuel handling systems” (EN 746-2) when used with fuels and oxidants.

The BCU 4 is suitable for continuous operation (pursuant to EN 298:2012-12, Section 3.126) and for intermittent operation (pursuant to EN 298:2012-11, Section 3.127).

#### Type of action

The automatic action corresponds to Type 2 pursuant to EN 60730-1.

#### Behaviour under fault conditions

Switching off the safety-relevant output signals:  
The output signals are switched off electronically in accordance with the criteria of automatic action type B.V.AC.AD.AF.AG.AH (pursuant to EN 60730-2-5:2015, Section 6.4.3.).

Maximum reaction time in the event of a flame failure:  
This corresponds to the safety time during operation and can be parameterized to between 1 and 4 s.

Software class:  
Corresponds to software class C which operates in a similar double-channel architecture with comparison.

### 19.2 Interfaces

#### Electrical wiring

Type of wiring:

Attachment type X to EN 60730-1.

Grounding: via PE wire connection.

Internal voltages are neither SELV nor PELV. Floating contacts meet the requirements for SELV.

### 19.3 Communication

Safety over EtherCAT® technology (FSoE, FailSafe over EtherCAT) is used for K-SafetyLink communication. Safety over EtherCAT® is a registered trademark and patented technology licensed by Beckhoff Automation GmbH, Germany.

The K-SafetyLink technology complies with SIL 3 in accordance with EN 61508 and is standardized pursuant to IEC 61784-3-12 and ETG 5100.

Safety over EtherCAT® uses the fail-safe principle which means that a safe state is restored in the case of an inactive signal. In the case of communication errors, all signals are interpreted as inactive.

Safety-relevant data are transmitted on the basis of the black channel principle.

All devices connected to the communications system must meet the requirements for safety extra-low voltage (SELV/PELV) (EN 60730-1).

The end user must ensure the unique setting and parameterization of the SafetyLink address within the Ethernet network.

The setting and assignment of the addresses must be verified before commissioning using the verification procedure described in the extended documentation.

## **19.4 SIL and PL**

### **SIL Safety Integrity Level/PL Performance Level**

See page 122 (Safety-specific characteristic values for SIL and PL).

## 20 Maintenance

### Maintenance

The fail-safe outputs (valve outputs V1, V2, V3 and V4) of the power module are monitored for correct functioning. In the event of a fault, the system is set to a safe status using a second shut-down path (isolation of the valve outputs from the mains). In the event of a defect (e.g. fault E 36), the power module must be replaced.

Order No. for the power module, see type label:

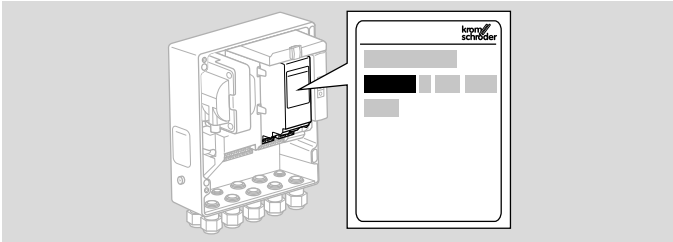

The device and user statistics can be displayed using the engineering tool BCSoft for further diagnostics and troubleshooting. The user statistics can be reset using engineering tool BCSoft.

## 21 Legend

Symbol	Description
	Ready for operation
	Safety interlocks (limits)
	Control element position check
	Controlled air flow
	Remote reset
LDS	Safety limits (limits during start-up)
	Gas valve
	Air valve
	Air/gas ratio control valve
	Pilot burner
	Main burner
	Purge
	External air valve control
	Flame signal, pilot burner
	Flame signal, main burner
	Operating signal, pilot burner
	Operating signal, main burner
	Fault signal
Start 1	Start-up signal, pilot burner (burner 1)
Start 2	Start-up signal, main burner (burner 2)
	Input for high temperature operation
	Pressure switch for tightness control (TC)
	Pressure switch for maximum pressure
	Pressure switch for minimum pressure
	Differential pressure switch
	Actuator with butterfly valve

Symbol	Description
	Valve with proof of closure switch
	Fan
	Three-point step switch
	Input/Output, safety circuit
TC	Tightness control
$p_u/2$	Half of the inlet pressure
$p_u$	Inlet pressure
$p_d$	Outlet pressure
$V_{p1}$	Test volume
$I_N$	Current consumption of sensor/contact
$t_L$	Tightness control opening time
$t_M$	Measurement time during tightness test
$t_P$	Tightness control test period ( $= 2 \times t_L + 2 \times t_M$ )
$t_{FS}$	Flame proving period
$t_{MP}$	Minimum pause time
$t_{NL}$	Over-run time
$t_{SA}$	Safety time on start-up
$t_{SB}$	Safety time during operation
$t_{VZ}$	Pre-ignition time
$t_{PV}$	Pre-purge time
$t_{RF}$	Controller enable signal delay time

## 22 Glossary

### 22.1 Waiting time $t_W$

In standby, the waiting time  $t_W$  starts to elapse in the background. During this time, a self-test is conducted to detect errors in internal and external circuit components. The burner will not be started during the waiting time. Any burner start will be delayed by the BCU 480 until the waiting time has elapsed.

### 22.2 Safety time on start-up $t_{SA1}$

This refers to the period of time between switching on and switching off of the gas valve, when no flame signal is detected. The safety time on start-up  $t_{SA1}$  is the minimum operating time of the burner 1 and burner control unit.

### 22.3 Safety time on start-up $t_{SA2}$

This refers to the period of time between switching on and switching off of the gas valve, when no flame signal is detected. The safety time on start-up  $t_{SA2}$  is the minimum operating time of the burner 2 and burner control unit.

### 22.4 Ignition time $t_Z$

If no malfunction is detected during the waiting time  $t_W$ , the ignition time  $t_Z$  then starts to elapse. Voltage is supplied to the pilot gas valve and the ignition transformer and the burner is ignited. The duration of the ignition time is either 1, 2, 3 or 6 s (depending on safety time  $t_{SA1}$  selected).

### 22.5 Safety time during operation $t_{SB}$

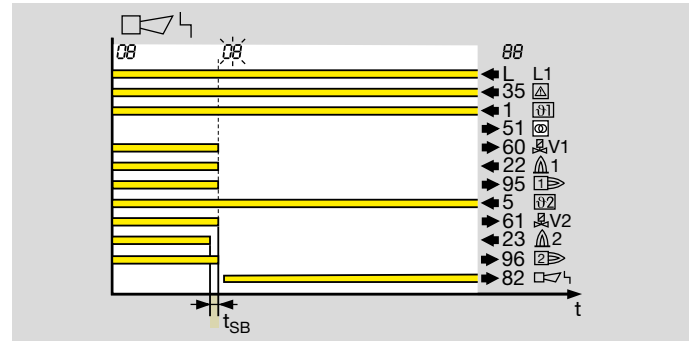

In the event of a flame failure during operation or an interruption of the safety current inputs, the fuel supply is interrupted within the safety time  $t_{SB}$ .

The default safety time during operation  $t_{SB}$  in accordance with EN 298 is 1 s. Under EN 746-2, the safety time of the installation during operation (including closing time of the valves) must not exceed 3 s. Note the requirements of the standards! Under NFPA 86, section 8.10.3\*, the maximum flame failure response time shall be  $\leq 4$  s.

### 22.6 Safety interlocks (Limits)

The limiters in the safety interlock (linking of all the relevant safety control and switching equipment for the use of the application, e.g. safety temperature limiter, minimum/maximum gas pressure) must isolate input (  $\triangle$  ) from the voltage supply.

### 22.7 Safety shut-down

The burner control unit performs a safety shut-down immediately after receiving a signal from a safety device or after a fault is detected (e.g. flame or air pressure failure). The safety shut-down prevents operation of the burner by closing the fuel shut-off valves and deactivating the ignition device.

For this, the BCU disconnects the gas valves and the ignition transformer from the electrical power supply. The operation signalling contact and the controller enable signal are deactivated. The fault signalling contact remains open. The display blinks and displays the current program step.

After a safety shut-down, the BCU can restart automatically.

### 22.8 Safety shut-down with subsequent lock-out (fault lock-out)

A fault lock-out is a safety shut-down with subsequent lock-out. The system can only be restarted following manual reset. The protective system cannot be reset by mains failure.

In the event of a fault lock-out of the BCU, the fault signalling contact closes, the display blinks and shows the current program step. The gas valves are disconnected from the electrical power supply. The fault signalling contact opens if the mains voltage fails.

In order to restart, the BCU can only be reset manually using the button on the front panel or the remote reset input (terminal 2).

### 22.9 Warning signal

The BCU reacts to operating faults, e.g. in the case of permanent remote resets, with a warning signal. The display

blinks and shows the corresponding warning message. The warning signal ends once the cause has been eliminated.

The program sequence continues. No safety shut-down or fault lock-out occurs.

### 22.10 Timeout

For some process faults, a timeout phase elapses before the BCU reacts to the fault. The phase starts as soon as the BCU detects the process fault and ends after 0 to 250 s. A safety shut-down or fault lock-out is then performed. If the process fault ends during the timeout phase, the process continues as before.

### 22.11 Air actuator

The air actuator can be used

- for cooling,
- for purging,
- to control the burner capacity in ON/OFF mode and in High/Low mode when using a pneumatic air/gas ratio control system.

## 22.12 Safe failure fraction SFF

Fraction of safe failures related to all failures, which are assumed to appear

see EN 13611/A2

## 22.13 Diagnostic coverage DC

Measure of the effectiveness of diagnostics, which may be determined as the ratio between the failure rate of detected dangerous failures and the failure rate of total dangerous failures

NOTE: Diagnostic coverage can exist for the whole or parts of a safety-related system. For example, diagnostic coverage could exist for sensors and/or logic system and/or final elements. Unit: %

see EN ISO 13849-1

## 22.14 Operating mode

IEC 61508 describes two modes of operation for safety functions. These are low demand mode and high demand or continuous mode.

In low demand mode, the frequency of demands for operation made on a safety-related system is not greater than one per year and is not greater than twice the proof-test frequency. In high demand mode or continuous mode, the frequency of demands for operation made on a safety-related system is greater than one per year or greater than twice the proof-test frequency.

See also IEC 61508-4

## 22.15 Probability of dangerous failure PFH<sub>D</sub>

Value describing the likelihood of dangerous failure per hour of a component for high demand mode or continuous mode. Unit: 1/h

see EN 13611/A2

## 22.16 Mean time to dangerous failure MTTF<sub>d</sub>

Expectation of the mean time to dangerous failure

see EN ISO 13849-1:2008

## For more information

The Honeywell Thermal Solutions family of products includes Honeywell Combustion Safety, Eclipse, Exothermics, Hauck, Kromschroder and Maxon. To learn more about our products, visit [ThermalSolutions.honeywell.com](https://ThermalSolutions.honeywell.com) or contact your Honeywell Sales Engineer.

Elster GmbH  
Strotheweg 1, D-49504 Lotte  
T +49 541 1214-0  
[hts.lotte@honeywell.com](mailto:hts.lotte@honeywell.com)  
[www.kromschroeder.com](http://www.kromschroeder.com)

© 2021 Elster GmbH

We reserve the right to make technical modifications in the interests of progress.

